



CERTIFICATE OF APPROPRIATENESS PLACARD

for Raleigh Historic Resources

Project Description:

Replace window

616 N Boundary St

Address

Oakwood

Historic District

Historic Property

COA-0105-2020

Certificate Number

8/27/2020

Date of Issue

2/27/2021

Expiration Date

This card must be kept posted in a location within public view until all phases of the described project are complete. The work must conform with the code of the City of Raleigh and laws of the state of North Carolina. When your project is complete, you are required to ask for a final zoning inspection in a historic district area. Telephone the RHDC office at 832-7238 and commission staff will coordinate the inspection with the inspections Department. If you do not call for this final inspection, your Certificate of Appropriateness is null and void.

Signature, _____

A handwritten signature in blue ink that reads "Erin Mocton".

Raleigh Historic Development Commission

Pending the resolution of appeals, commencement of work is at your own risk.

Type or print the following:

Applicant name: Dan Chaksupa

Mailing address: 616 North Boundary St

City: Raleigh

State: NC

Zip code: 27604

Date: 07/06/2020

Daytime phone #: 919-824-4660

Email address: dchaksupa@yahoo.com

Applicant signature:

Minor work (staff review) – one copy
 Major work (COA committee review) – ten copies

- Additions > 25% of building sq. footage
- New buildings
- Demolition of building or structure
- All other

Post approval re-review of conditions of approval

Office Use Only

Transaction #: _____
 File #: COA-0105-2020
 Fee: _____
 Amount paid: _____
 Received date: _____
 Received by: _____

Property street address: 616 North Boundary St.

Historic district: Oakwood

Historic property/Landmark name (if applicable): none

Owner name: Dan Chaksupa

Owner mailing address: 616 North Boundary St.

For applications that require review by the COA Committee (major work), provide addressed and stamped envelopes for owners for all properties with 100 feet on all sides of the property, as well as the property owner.

Property Owner Name & Address	Property Owner Name & Address

I understand that all major work applications that require review by the Raleigh Historic Development Commission’s COA Committee must be submitted by 4 p.m. on the date of the application deadline; otherwise, consideration will be delayed until the following committee meeting. An incomplete application will not be accepted.

<p>Will you be applying for rehabilitation tax credits for this project? Yes <input type="radio"/> No <input checked="" type="radio"/></p> <p>Did you consult with staff prior to filing the application? Yes <input checked="" type="radio"/> No <input type="radio"/></p>	<p style="text-align: center;">Office Use Only</p> <p>Type of work: <u>84</u></p> <hr/>
---	---

Design Guidelines: please cite the applicable sections of the design guidelines (www.rhdc.org).		
Section/Page	Topic	Brief description of work (attach additional sheets as needed).
15	window	removal of existing window/still and installation of new window.

<p>Minor Work Approval (office use only)</p> <p>Upon being signed and dated below by the Planning Director or designee, this application becomes the Minor Work Certificate of Appropriateness. It is valid until <u>02/27/2021</u>.</p> <p>Please post the enclosed placard form of the certificate as indicated at the bottom of the card. Issuance of a Minor Work Certificate shall not relieve the applicant, contractor, tenant, or property owner from obtaining any other permit required by City Code or any law. Minor Works are subject to an appeals period of 30 days from the date of approval.</p> <p>Signature (City of Raleigh) _____ Date <u>08/27/2020</u></p>
--

July 6, 2020

Dear Sir or Ma'am,

I am submitting this plan for a minor work on my home at 616 North Boundary Street. A double hung, grill-less window on the east-facing side of the house has substantial wood rot at the sill as well as the window frame itself, necessitating its replacement. I plan to have it replaced with a double hung grill-less window of the same style and material.

Cordially,

A handwritten signature in black ink, appearing to read 'Dan Chaksupa', with a stylized flourish at the end.

Dan Chaksupa

ALL-WOOD WINDOWS APPROVED.
CLAD WINDOWS NOT APPROVED.

UNIT SECTIONS
Primed Wood Exterior
LX Double-Hung

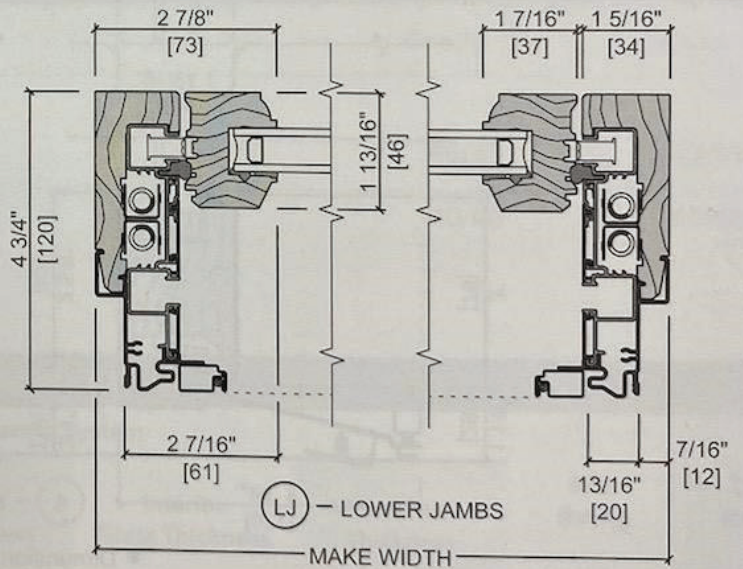
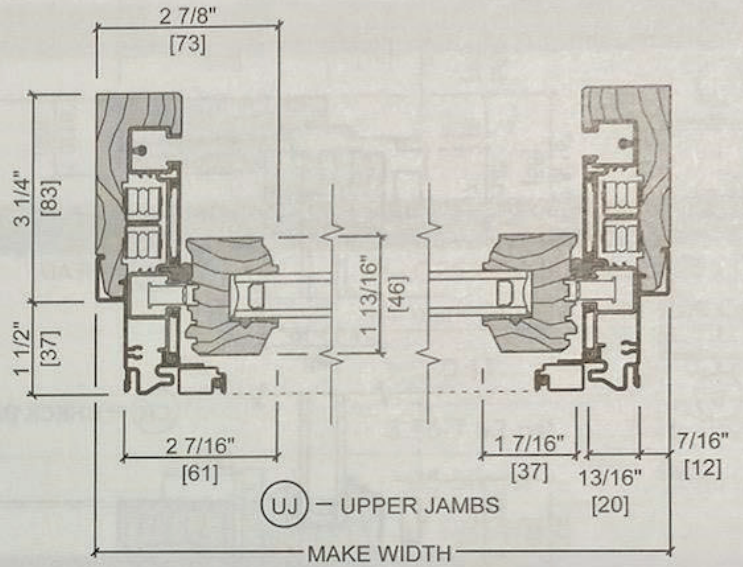
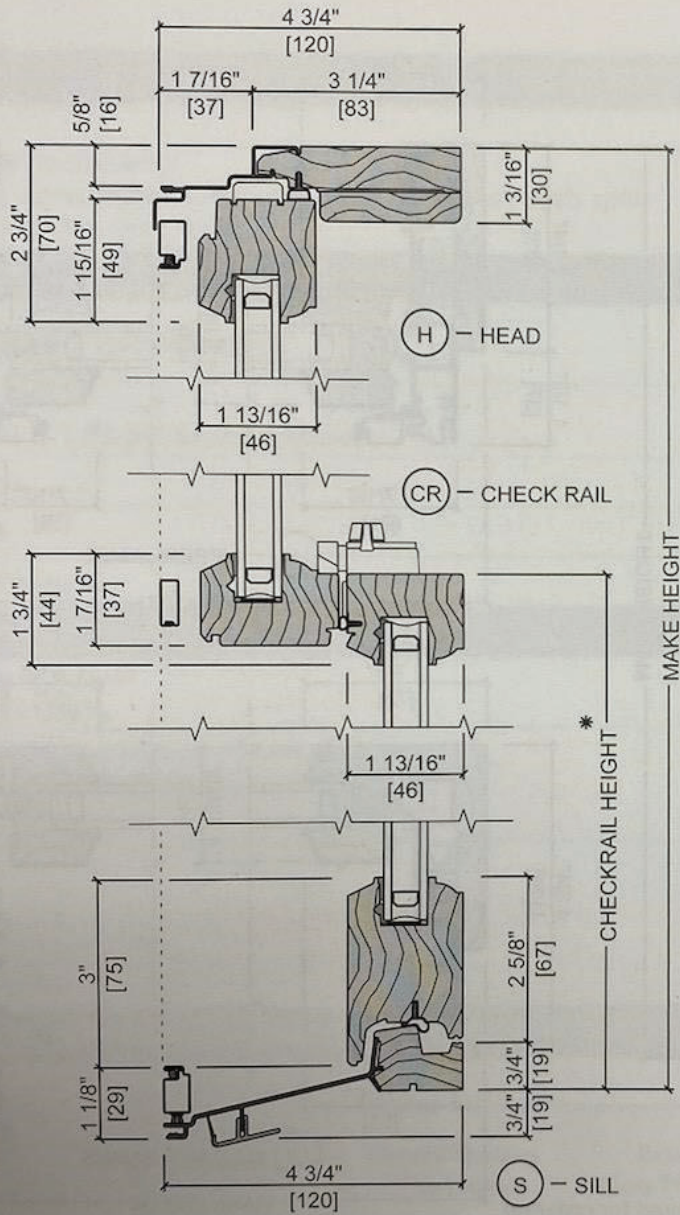

* Dimension required for ordering units with unequal sash.



616







Pella® Reserve™

Traditional Wood & Clad/Wood



Exquisitely designed windows and doors with unparalleled historical detailing.

Double-Hung Interior



Double-Hung Exterior



- Historical details**
 Our most historically authentic line of wood windows and patio doors. Featuring through-stile construction, deliberate proportions and intricate profiles. Pella Reserve products are the ideal choice for historical renovations and traditional building projects.
- Authentic hardware**
 Complement your project with historically authentic spoon-lock window hardware. Our Antiek casement window hardware is inspired by period furniture to deliver authentic traditional style.
- Architectural interest**
 Featuring the industry's only foam spacer solution, Pella's Integral Light Technology® grille helps capture the look of true-divided-light without sacrificing energy performance. Further your aesthetic with the putty profile, recreated with historically accurate angles – providing meaningful depth and a realistic shadow. Pella Reserve products offer the industry's deepest sash dimension.
- Virtually unlimited customization**
 If you can dream it, we can build it with our most customizable product line. From extra tall to extra wide, Pella can craft unique windows that complement your aesthetic. Custom sizes, grille patterns and designs, finishes, wood types and glass options are available.
- Tailor-made solutions**
 From preliminary drawings to installation, Pella's expert team of architects, engineers, drafters and consultants can work to deliver custom window and door solutions for your project. Partner with Pella to achieve your unique vision without concessions.
- Intentional innovation**
 Winner of the 2019 Most Innovative Window from Window and Door Magazine, the Integrated Rolscreen® retractable screen preserves aesthetic view. It is a double- and single-hung screen that appears when you open the window, and rolls away, out of sight, when you close it.
- Durable interiors and extruded aluminum exteriors**
 Create a custom exterior color to meet your design needs or choose from 27 standard color options. Interior finish options are available in four paints, eleven stains and primed and ready-to-paint.
- ENERGY STAR® certified¹**
 Pella wood products offer energy-efficient options that will meet or exceed ENERGY STAR guidelines in all 50 states. Pella Reserve products with triple-pane glass have been awarded the ENERGY STAR Most Efficient Mark in 2020.¹
- Testing beyond requirements**
 At Pella, our products are tested beyond requirements to help ensure they have long-lasting performance and reduce call-backs for you.
- Best limited lifetime warranty²**
 Pella Reserve products are covered by the best limited lifetime warranty in the business for wood windows and patio doors.²

Available in these window and patio door styles:



Special shape windows also available.

^{1,2} See back cover for disclosures.

Product Specifications

Window & Patio Door Styles	Min. Width	Min. Height	Max. Width	Max. Height	Performance Class & Grade	Performance Values			Frame / Install
						U-Factor	SHGC	STC	
Awning	13-3/4"	13-3/4"	53"	29"	LC40-CW50	0.25-0.29	0.18-0.47	27-33	Fold-out Fin, Block Frame, EnduraClad Exterior Trim / Brickmould
Precision Fit Awning	17"	17"	53"	29"	R50-CW50	0.28-0.32	0.18-0.47	27-33	Pocket Replacement
Casement	13-3/4"	13-3/4"	41"	96"	R35-CW50	0.25-0.29	0.18-0.47	27-35	Fold-out Fin, Block Frame, EnduraClad Exterior Trim / Brickmould
Precision Fit Casement	17"	17"	35"	73"	R45-CW50	0.28-0.33	0.18-0.47	27-30	Pocket Replacement
Fixed Casement	10"	10"	144"	144"	R35-CW50	0.25-0.29	0.18-0.47	27-35	Fold-out Fin, Block Frame, EnduraClad Exterior Trim / Brickmould
Precision Fit Fixed Casement	17"	17"	59"	73"	R45-CW50	0.28-0.33	0.18-0.47	27-30	Pocket Replacement
Double-Hung	14"	24-3/8"	48"	96"	CW40-CW50	0.25-0.30	0.19-0.53	26-34	Fold-out Fin, Block Frame, EnduraClad Exterior Trim / Brickmould
Precision Fit Double-Hung	13-1/2"	23-3/4"	48"	84"	CW40-CW50	0.25-0.31	0.19-0.53	26-30	Pocket Replacement
Monumental Hung	13-3/4"	24"	72"	144"	LC25-CW50	0.25-0.30	0.17-0.47	29-34	Fold-out Fin, Block Frame, EnduraClad Exterior Trim / Brickmould
In-Swing Hinged Patio Door (Single)	18"	36"	48"	199-1/2"	LC40-LC55	0.25-0.29	0.14-0.40	31-32	
In-Swing Hinged Patio Door (Double)	36"	36"	96"	119-1/2"	LC40-LC55	0.25-0.29	0.14-0.40	31-32	
Out-Swing Hinged Patio Door (Single)	18"	36"	48"	119-1/2"	R50-LC70	0.25-0.30	0.14-0.39	30-32	
Out-Swing Hinged Patio Door (Double)	36"	36"	96"	119-1/2"	R50-LC70	0.25-0.30	0.14-0.39	30-32	
Sliding Patio Door (O)	30-3/4"	74"	60-3/4"	119-1/2"	LC25-LC70	0.29-0.32	0.15-0.42	-	
Sliding Patio Door (OX, XO)	59-1/4"	74"	119-1/2"	119-1/2"	LC25-LC70	0.29-0.32	0.15-0.42	29-35	
Sliding Patio Door (OXO)	90"	74"	180"	119-1/2"	LC25-LC70	0.29-0.32	0.15-0.42	-	
Sliding Patio Door (OXXO)	116-1/8"	74"	236-1/8"	119-1/2"	LC25-LC70	0.29-0.32	0.15-0.42	-	
Multi-Slide Patio Door	40-1/4"	50-1/2"	701-5/8"	119-1/2"	R15-LC25 ³	0.30 - 0.36	0.15 - 0.46	-	
Bifold Patio Door	31-3/4"	55-1/2"	312"	119-1/2"	R15-R25 ³	0.26-0.44	0.13-0.45	-	For more info visit PellaADM.com

Window sizes available in 1/8" increments

Special sizes available. For more information regarding performance, visit installpella.com/performance. For more information regarding frame and installation types, visit PellaADM.com.

Grilles

Integral Light Technology®

Choose the look of true divided light featuring the industry's only foam spacer.

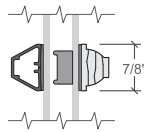

Putty Glaze Exterior with Ogee Interior⁴
5/8", 7/8", 1-1/4" or 2"

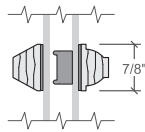

Putty Glaze Exterior with Ogee Interior⁴
5/8", 7/8", 1-1/4" or 2"

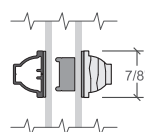

Ogee Exterior with Ogee Interior⁴
5/8", 7/8", 1-1/4" or 2"

Cross Sections

Cross Sections

The double-hung cross sections provide visual reference to the historic putty exterior profile and traditional, beveled Ogee interior that add architectural interest to your project.

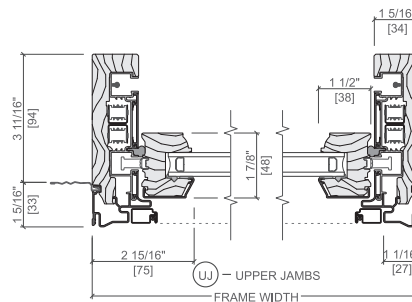

Optional Fold-out Installation Fin

^{3,4} See back cover for disclosures.

Window Hardware

Classic Collection

Get a timeless look with authentic styles in classic finishes.



Fold-away Crank
Antiek



Spoon-Style Lock

Finishes:



Champagne

White

Brown

Matte Black

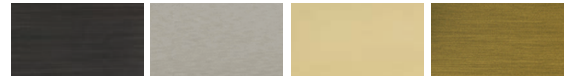

Oil-Rubbed Bronze

Satin Nickel

Bright Brass

Antique Brass

Rustic Collection

Create a distinct and charming look with distressed finishes.



Fold-away Crank
Antiek



Spoon-Style Lock

Finishes:



Distressed Bronze

Distressed Nickel

Essential Collection

Select from popular designs and finishes to suit every style.



Fold-away Crank



Cam-Action Lock

Finishes:

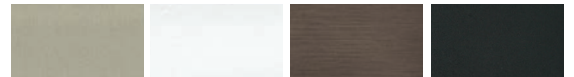

Champagne

White

Brown

Matte Black

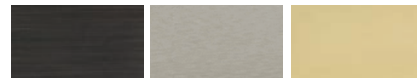

Oil-Rubbed Bronze

Satin Nickel

Bright Brass

Patio Door Hardware

Classic Collection

Choose timeless pieces, created in collaboration with Baldwin® Hardware, for a look that will never go out of style.

BALDWIN



Hinged & Bifold Patio Door Handle
Locus | Virago



Sliding & Multi-Slide Patio Door Handle
Ambrose



Multi-Slide Patio Door Handle^{5,6}

Finishes:

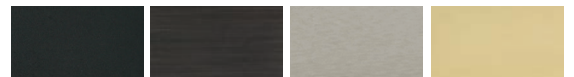

Matte Black

Oil-Rubbed Bronze

Satin Nickel

Bright Brass



Antique Brass

Essential Collection

Elevate your style and transform a home with elegant selections.



Hinged & Bifold Patio Door Handle



Sliding Patio Door Handle



Multi-Slide Patio Door Handle^{5,6}

Finishes:

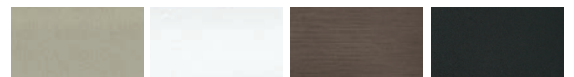

Champagne

White

Brown

Matte Black

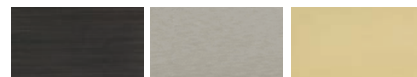

Oil-Rubbed Bronze

Satin Nickel

Bright Brass

^{5,6} See back cover for disclosures.

Colors

Wood Types

Choose the wood species that best complements your project's interior.



Prefinished Pine Interior Colors

Custom interior finishes, unfinished or primed and ready-to-paint are also available.

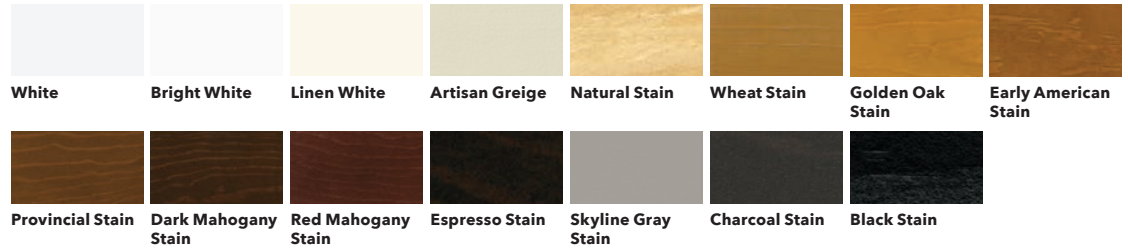

Extruded Aluminum-Clad Exterior Colors

Our low-maintenance EnduraClad® exterior finish resists fading. Take durability one step further with EnduraClad Plus which also resists chalking and corrosion.⁷



Custom colors are also available.

Added Peace of Mind

Integrated Security Sensors

Integrated wireless security sensors maintain aesthetics, streamline security installation and ensure no warranty loss is caused by post-installation drilling. Sensors can be monitored via the free Pella® Insynctive® App and are compatible with major security panel systems.⁸ For more information, go to connectpella.com.



The confidence of Pella's warranty.

Pella® Reserve™ products are covered by the best limited lifetime warranty for wood windows and patio doors.²

¹ Some Pella products may not meet ENERGY STAR® guidelines in Canada. For more information, contact your local Pella sales representative or go to energystar.gc.ca.

² Based on comparing written limited warranties of leading national wood window and wood patio door brands. See written limited warranty for details, including exceptions and limitations, at installpella.com/warranties or contact Pella Customer Service.

³ Ratings are contingent on product configurations.

⁴ Color-matched to your product's interior and exterior color.

⁵ Flush multi-slide handle is a Pella exclusive design.

⁶ Flush multi-slide handle is not available in Antique Brass, Champagne or Polished Nickel.

⁷ EnduraClad Plus protective finish is not available with all colors. See your local Pella sales representative for availability.

⁸ Requires the Insynctive App on a smart device, an Insynctive Bridge and a wireless home router with internet connection.



It's time to fall in love with your home all over again.

Whether you're replacing your old windows because they're broken, drafty, or require too much maintenance, we know you have lots of questions. There are many considerations—glass, window frame material, style, hardware, color and warranty to name a few. But most importantly, you want the job done right. You want it to be a smooth, easy process, and you want it to be done by a company you can trust before, during and after installation.

That's why you want Renewal by Andersen. We offer a start-to-finish process. All you need to do is sit back and relax, knowing you made the right choice in window replacement.



Renewal by Andersen.
WINDOW REPLACEMENT an Andersen Company

The *Better Way* to
a *Better Window*®



Double-Hung Windows and Picture Window / White Exterior / Colonial Grilles

The Renewal by Andersen Process is Easy ...



Get Started

Give us a call, visit our website or stop by one of our showrooms to schedule a **FREE** in-home consultation.



Set Up a Time to Meet

We will meet in the comfort of your home at a time convenient for you to discuss your project.



Sit Back and Relax

You've selected a professional company that can handle the entire replacement process from start-to-finish.



CONTENTS

The Renewal by Andersen Difference	2
Innovation	4
Choosing Windows	6
Double-Hung Windows	8
Casement and Awning Windows	10
Gliding Windows	12
Picture Windows	14
Specialty Windows	16
Bay and Bow Windows	18
Grille Options	20
Insect Screen Options	22
Hardware Finish Options	23
Choosing Patio Doors	24
Frenchwood® Hinged Patio Doors	25
Frenchwood® Gliding Patio Doors	26
Narrolme® Gliding Patio Doors	27
Perma-Shield® Gliding Patio Doors	28
Patio Door Hardware Options	29
Patio Door Engineering	30
Patio Door Options	31
Glass Options	32
Warranty	BACK

The Renewal by Andersen® Difference

Over 3 million windows installed.

Peace of Mind Comes Standard

Renewal by Andersen is the exclusive start-to-finish window replacement subsidiary of Andersen Corporation, the most recognized window brand in the United States.

We were founded with a mission to change the window replacement industry by offering a 'different and better' window replacement experience. We own the process from sales through installation and service, and we promise one-stop accountability.

See for yourself the difference our standards for quality and service will make in your window and door replacement experience. We make it easy.

Start-to-Finish Process

+ Experience

Professional Installation

+ Innovative Materials

+ Limited Warranty

= Complete Customer Satisfaction



Never worry about scraping or painting¹ your windows again!

An Unmatched History

Founded in 1903, Andersen Corporation quickly revolutionized the way windows were built and installed. Over the years, Andersen has introduced many industry firsts. Andersen continues to be a leader in producing products that last longer, look better and function smoothly for many years.

To this day, Andersen Corporation operates under the core principles founder Hans Andersen put in place over a century ago. When you purchase Renewal by Andersen windows, you're purchasing time-tested innovation, and a piece of history that will last for years to come!



OVER 114 YEARS
Innovation
AND
Excellence

Customer Service



Our professional sales consultants and expert installation teams are with you every step of the way.

Our installers are experienced and understand the many critical steps involved with installing your new windows and doors properly.



Products



Professional Installation

Limited Warranty



We offer one of the strongest limited warranties of any window and door manufacturer and it is fully transferable should you sell your home!

Customer-Focused Engineering and Innovation

Years of proven innovation results in products and people you can trust.

Exterior

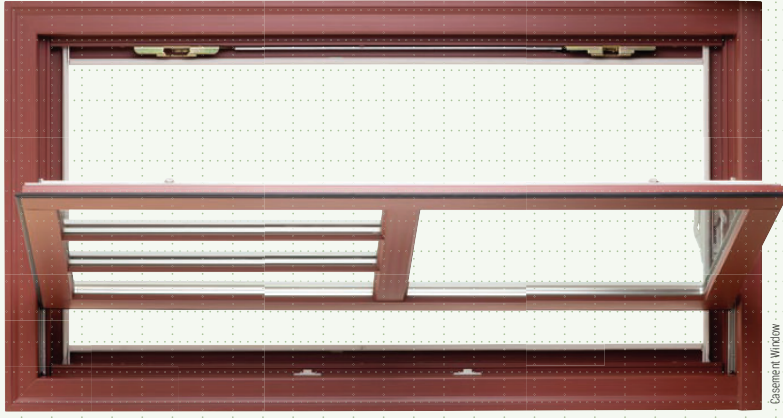

Casement Window
Red Rock Exterior
Simulated Double-Hung Farmhouse Grilles

FUNCTIONAL REQUIREMENTS:

- Thermal analysis
- Structural analysis

ENGINEERING SOLUTION:

- Increase product performance

HOMEOWNER BENEFIT:

A strong balance of energy efficiency and strength, offering some of the largest casement window sizes.



STANDARD FEATURE

FUNCTIONAL REQUIREMENTS:

- Hardware mechanics

ENGINEERING SOLUTION:

- Low profile hardware with fold-down nesting handle

HOMEOWNER BENEFIT:

Nesting casement window hardware reduces interference with window treatments.

FUNCTIONAL REQUIREMENTS:

- Strengthen corner joints
- Increase window beauty

ENGINEERING SOLUTION:

- Utilize mortise-and-tation corner joint

HOMEOWNER BENEFIT:

Unique corner key design increases structural integrity and beauty.



FUNCTIONAL REQUIREMENTS:

- Ease of cleaning

ENGINEERING SOLUTION:

- Incorporate hardware that allows for accessibility

HOMEOWNER BENEFIT:

Ease and safety while cleaning your new windows – no more ladders!



With safety and convenience in mind, our double-hung, casement and glazing windows are easy to clean from the interior of your home.

Interior

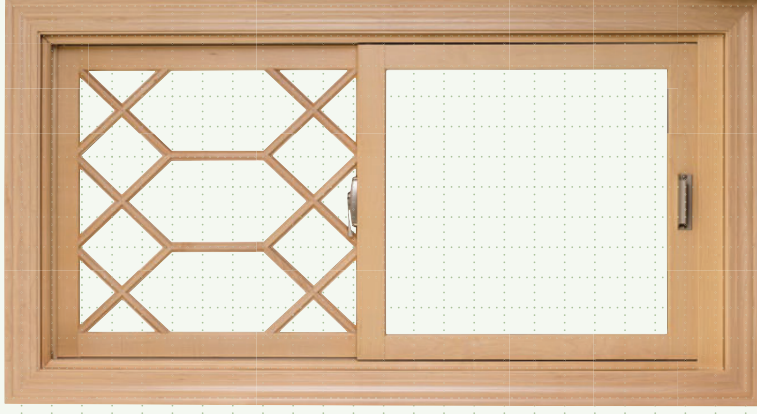

Double-Hung Window
Pine Interior / Custom Grilles
Satin Nickel Estate Hardware

FUNCTIONAL REQUIREMENTS:

- Reduce air infiltration

ENGINEERING SOLUTION:

- Integrate weatherslips into side joints

HOMEOWNER BENEFIT:

Reinforced seals provide a high level of protection against drafts.

FUNCTIONAL REQUIREMENTS:

- Water management

ENGINEERING SOLUTION:

- Grooving
- Angled sill

HOMEOWNER BENEFIT:

Sloped sill drains water away from the window.



FUNCTIONAL REQUIREMENTS:

- Join design options and technical compatibility

ENGINEERING SOLUTION:

- Integrate interior and exterior grilles into window design

HOMEOWNER BENEFIT:

Add grilles to the inside, outside and even between the glass of your new window.



FUNCTIONAL REQUIREMENTS:

- Window operation

ENGINEERING SOLUTION:

- Incorporate balancer system

HOMEOWNER BENEFIT:

Effortless opening and closing of window.

What are Renewal by Andersen® windows made of?

All of our windows are made of Fibrex® material, a revolutionary composite made from reclaimed wood fiber blended with a polymer. This gives our windows the strength and durability of wood, and the low-maintenance features of vinyl while greatly limiting thermal transmittance found in other window materials such as metal.

Warranted not to flake, rust, blister, peel, crack, pit, or corrode.†

SMART MATERIALS

Fibrex® material is twice as strong as vinyl, so weathertight seals stay weathertight.

COLOR CHOICE

Our unique process fuses color to Fibrex® material for long-lasting beauty as well as offering dark exterior colors not available on most other replacement windows.

EXCEPTIONAL COMFORT

Fibrex® material blocks thermal transfer nearly 700 times better than aluminum to help reduce heating and cooling bills.

EXCEPTIONAL DURABILITY

Fibrex® material retains its stability and rigidity in all climates!

Fibrex®	Aluminum	Fiberglass	Vinyl	Wood
Insulating Properties	✓	✓	✓	✓
Low Maintenance	✓	✓	✓	✓
Resistance to Decay/Corrosion	✓	✓	✓	✓
Structural Rigidity	✓	✓	✓	✓
Durable	✓	✓	✓	✓
Color/Finish Choices	✓	✓	✓	✓
Maximum Glass Area	✓	✓	✓	✓
Dark Color Performance	✓	✓	✓	✓

ENGINEERED WITH
FIBREX®

Andersen
EXCLUSIVE FEATURE

Choosing Renewal by Andersen® Windows is Easy...

The Renewal by Andersen process starts with our consultative sales approach. Our experienced sales representatives will work with you to find solutions to enhance your home's functionality, energy efficiency and beauty.

1

Select Window Styles

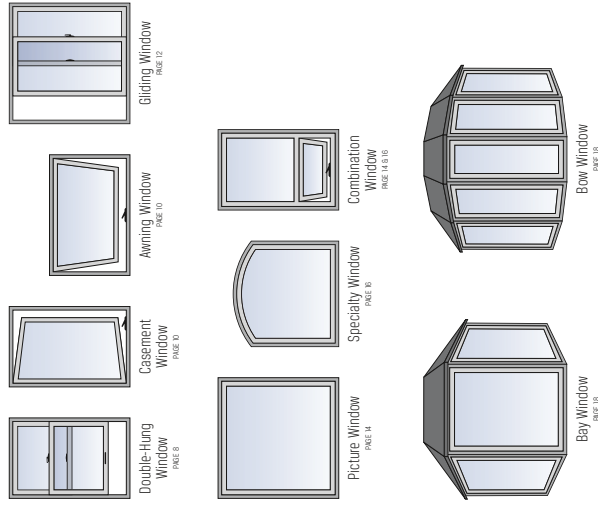

2

Select Colors²

Real wood interiors can be stained or painted to match your decor



3

Select Hardware and Options



We make it easy so you can sit back and relax knowing you've selected a professional start-to-finish window replacement company.



Visit Us Online at RENEWALBYANDERSEN.COM



See independent homeowner reviews and completed projects from your neighborhood.



Explore how new windows will look in your home.



Get ideas and be inspired by our window options.



Five Key Environmental and Energy Solutions

While we care about you and your home, we also care deeply for the world in which we all live.



See our Environmental and Energy Solutions Brochure for additional information.

Double-Hung Windows

This classic window style is an excellent choice no matter where you live. Choose gently curved Contemporary or squared Traditional Check Rails.

CONVENIENT
Easy cleaning from the inside.

ACCURATE
Appropriate for restoration and renovation projects.

ELEGANT
Traditional look of mortise-and-tenon styling.



Double-Hung Equal Window



Double-Hung Cottage Style Window



Double-Hung Reverse Cottage Style Window

Check Rail Options



Contemporary



Traditional

Reverse cottage style windows feature a larger upper sash.



Double-Hung Windows / White / Colonial Grilles



Double-Hung Reverse Cottage Style Windows Maple Interior / Modified Prairie Grilles



Double-Hung Windows / White Interior



Double-Hung Cottage Style and Picture Combination Window / White Interior / Colonial Grilles



Double-Hung and Double-Hung Cottage Style Windows / White Exterior / Colonial Grilles



"My new windows look beautiful and can be opened from the bottom or top."
CAROL P.

Casement and Awning WINDOWS

Casement windows catch a breeze and direct fresh air indoors, allowing the most ventilation of any window style. Awning windows let in fresh air, even on rainy days!

EASY

Casement windows open wide to allow easy cleaning of outside glass from the inside¹ and can be hinged from the right or left.

SECURE

One lever positioned in an easy-to-reach location, securely locks the casement window at multiple points for a weathertight seal.

EFFICIENT

Casement and awning windows are our most energy-efficient ventilating window styles.

CONVENIENT

Awning windows are recommended for use over cabinets, counters, or areas where opening and closing require a reach.



Casement Window

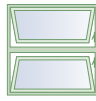

Casement Double Window



Awning Window

Use grilles to mimic the appearance of double-hung windows for a historically accurate look



Casement and Specialty Equal Leg Arch Combination Window / Oak Interior / Colonial Grilles

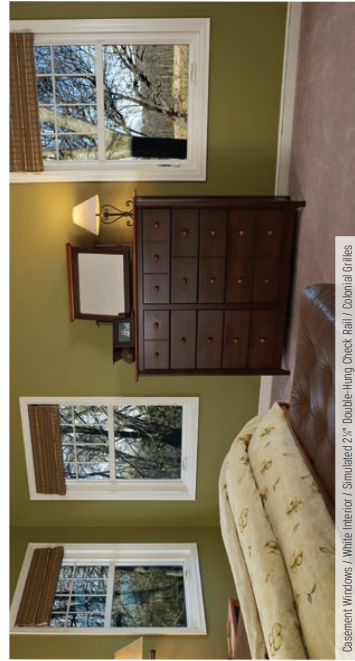

Casement Windows / White Interior / Simulated 2x4 Double-Hung Check Rail / Colonial Grilles



Awning Window / Pine Interior

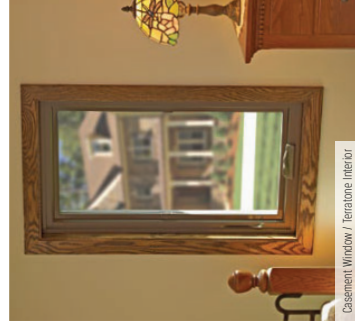

Casement Window / Teratone Interior



Casement and Picture Combination Windows / Oak Interior

“Renewal by Andersen was by far the best investment I’ve ever made for my home.”
PAUL M.

Gliding WINDOWS

Whether you're creating a new look or matching the original window style of your home, maximize your view with slim, easy to slide, contemporary gliding windows.

BEAUTIFUL

Narrow, contoured frames allow more glass viewing area.

VERSATILE

Both sashes slide, so you can open either the left side, the right side or a portion of both.*

RELIABLE

Fibrex® material tracks are shaped for easier cleaning and will not pit, rust or corrode!†

UNIQUE

A great solution when a projecting window may interfere with walkways, patios, decks, or landscaping.



Gliding Window



Gliding Fractional Vent Window



Gliding Triple Window

A great way for your room to look in natural light



Gliding Triple Window and Gliding Window / White Interior

Renewal
by Andersen
WINDOW REPLACEMENT



“Best investment in our home that we have made.”
STEVEN E.



Gliding Window / Maple Interior



Gliding Triple Window / White Interior



Picture Window left, Gliding Window center and Specialty Window right / Oak Interior



Gliding Triple Window and Gliding Fractional Vent Window Terracotta Interior

How Window Performance is Rated

Energy Efficiency Rating

To help homeowners, in 1992 the National Fenestration Rating Council (NFRC) established an independent third party rating, certification and labeling program for windows, doors and skylights (fenestration products). Renewal by Andersen displays the NFRC label on all of its windows. This label means that the entire window unit has been rated and certified, not just the center of the glass or individual components. See our Energy Efficiency brochure for additional information.

	Renewal by Andersen Certified Picture Window Double-Pane Low-E Insulation Product Type: Fixed	ENERGY PERFORMANCE RATINGS U-Factor (U-Value) 0.26 Solar Heat Gain Coefficient (SHGC) 0.23
ADDITIONAL PERFORMANCE RATINGS Visible Transmittance 0.53		Sample label shown

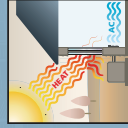

Warm Weather Performance



Cool Weather Performance

* Also available with stationary sash, where one sash is not movable.

Picture WINDOWS

Transform your home with picture windows that can stand alone beautifully or can be combined with other window styles for added curb appeal.

- ADAPTABLE**
Match or change your home's appearance by combining picture windows with other windows.
- STRONG**
Using strong Fibrex® material frames, our picture windows easily support the weight of the heavy glass commonly needed for large picture windows.
- VERSATILE**
Like all of our windows, picture window glass is available tempered, tinted, or in a wide variety of decorative patterns.



EXPLORER
SOUTH
STYLE



14 RENEWALBYANDERSEN.COM



Renewal
by Andersen
WINDOW REPLACEMENT

“The new windows are gorgeous and receive rave reviews from our visitors.”

ROBERT R.



Picture Window / White Interior

Schedule Your FREE In-Home Consultation

- Call your local Renewal by Andersen representative
- Click over to RENEWALBYANDERSEN.COM
- Visit your local Renewal by Andersen showroom



Picture Window / Sandstone Interior



Picture and Specialty Equal Leg Arch Combination Window / Oak Interior

Specialty WINDOWS

As unique as your home, our specialty windows are custom-made and available in many configurations.

VERSATILE

Specialty windows are available in thirteen different shapes and a wide variety of colors, grille patterns and glass options.

STRONG

Like picture windows, specialty windows don't open, but can be joined to any other window style for maximum design flexibility.¹



Circle
Renaissance
Grilles



Circle Top
Open Hub
Sunburst Grilles



Quarter Circle
Sunburst Grilles



Chord
Sunburst Grilles



Springline
Gothic Grilles



Springline
Unequal
Renaissance
Grilles



Arch
Equal Leg
Prairie Grilles



Arch
Unequal Leg
Prairie Grilles



Trapezoid
Colonial Grilles



Triangle
Colonial Grilles



Peak Pentagon
Prairie Grilles



Right Triangle
Prairie Grilles



Pentagon
Prairie Grilles



Octagon
Colonial Grilles



Hexagon
Colonial Grilles

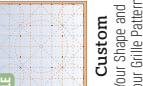

Custom
Your Shape and
Your Grille Pattern



Combination Window



Specialty Equal Leg Arch, Specialty Unequal Leg Arch and Picture Combination Window / Oak Interior

Renewal
by Andersen
WINDOW REPLACEMENT



Specialty Springline™ Window Addressing Fenestration™ Insulating Patio Door / White Interior

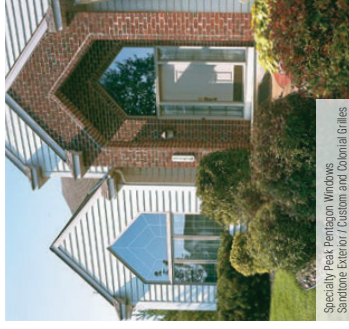

Specialty Peak Pentagon Windows / Sandstone Exterior / Colonial and Colonial Grilles

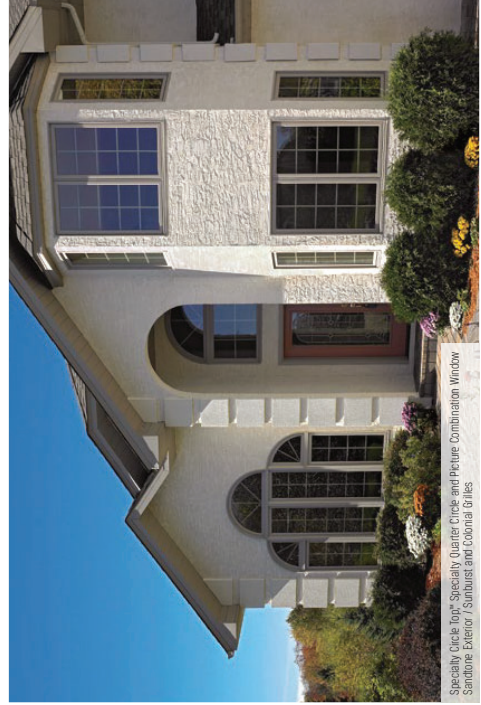

Specialty Circle Top™ Specialty Quarter Circle and Picture Combination Window Sandstone Exterior / Sunburst and Colonial Grilles



Specialty Circle Top™ and Casement Combination Windows / Creams Interior

¹Select specialty windows are made of alternate composite formulations to optimize construction and quality.

Projection WINDOWS

Expand the possibilities with an elegant, gently arched bow window or an angled bay window to make your home feel larger and brighter. Make any room a masterpiece.

VERSATILE

Bay and bow windows can be used as a replacement in most large window openings.

FLEXIBLE

Choose a combination of double-hung, casement, picture or awning windows.

BOW

Bow windows sweep away from the wall in a graceful arch of three, four, five or six windows.

BAY

Bay windows are available in four projection angles up to a 90° box bay.

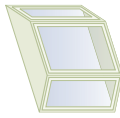

Bay Window

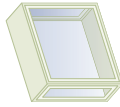

Box Bay Window



Bump-Out Bay Window



Bow Window

EXPRESS YOUR STYLE

Roof Options⁶

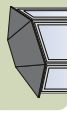

Hip Roof

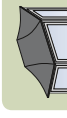

Concave Roof



Painted Aluminum



Copper



Shingles



Stone



More Options Available



More Options Available

EXPRESS YOUR STYLE

Seat Color Options⁶



Real Birch



Real Oak



Beech



Cameo White Avonite[®]



Tongue and Groove[®]



Sandstone Avonite[®]



Dusk Avonite[®]



SEE OUR BOOKSTORE



Bay Window / White Interior

Renewal
by Andersen
WINDOW REPLACEMENT

"Thank you for making our house look beautiful!"

JON M.



Bow Window / Oak Interior / Colonial Grilles



Bow Window / Terrapine Exterior / Concave Copper Roof



Bow Window / Canvas Exterior / Shale Roof



Bay Window Casement and Picture Windows / Oak Interior

⁶ Other options may be available. Ask your sales representative for details. ⁷ Available in Real Maple or Real Oak. Ask your sales representative for details.

Grille options

Customize Your Windows

Renewal by Andersen offers a wide range of creative grille patterns to enhance the look of your home.

All of our grilles are designed to be long-lasting with low-maintenance performance. With such a broad range of high-profile grille options, you can match your home's current architecture, change the look and style of your home or incorporate them into a renovation project for historical accuracy.

Patterns

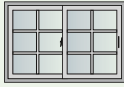

Colonial

Specific number of squares per sash.
Double-hung window shown

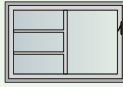

Farmhouse

Two vertical bars meet a wider horizontal rail or bar at the center of the window.
Casement window shown

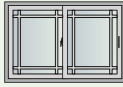

Prairie

Two vertical and two horizontal bars per sash to form 4 inch corner squares.
Double-hung window shown

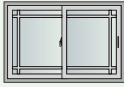

Modified Prairie

Two vertical bars and one horizontal bar per sash.
Double-hung window shown

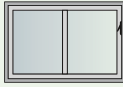

Simulated Double-Hung

Preserve the look of a traditional window.
Casement window shown



PERMANENT



REMOVABLE

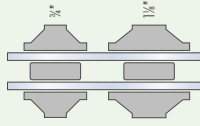

3/4"

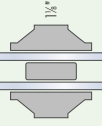

1/4"

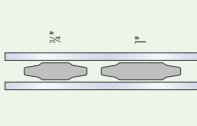

3/4"

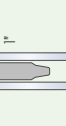

1"

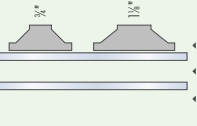

3/4"

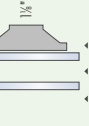

1/4"

Home Interior
Between Sash
Home Exterior

Profiles

Fractional

Specific number of vertical bars and horizontal bar.
Casement window shown



Equal Light

Specified number of horizontal bars, equal distance apart.
Casement window shown



Custom

Create a new pattern or revive one from the past.
Casement window shown with short fractional diamond custom pattern



More

Ask your replacement consultant for more grille options.
Picture window shown



Picture Windows / Pine Interior / Colonial Grilles



Casement and Double-Hung Windows / White Exterior / Colonial Grilles



Double-Hung Windows / White Exterior / Modified Prairie Grilles

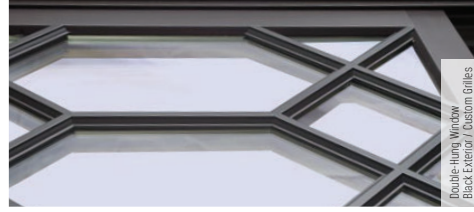

Double-Hung Window Black Exterior / Custom Grilles

¹ See Renewal by Andersen® Products and Installation Handbook Limited Warranty for details.

Insect Screen options

Even when it comes to screens, you can let your personal style guide you.

Repel Invaders

Insect screens are included on every operable Renewal by Andersen® window. Each is lightweight and designed to be easily removed from the inside of your home for easy cleaning. All insect screens are constructed with an aluminum frame and your choice of fiberglass, aluminum or our innovative TruScene® insect screens. Half insect screens are available on double-hung windows.

Keeps out more bugs



EXCLUSIVE FEATURE



EXCLUSIVE FEATURE

TruScene® Insect Screen



TruScene® insect screens are like nothing you've ever seen!

High Transparency

TruScene® Insect Screen

With over 50% more clarity than our standard insect screen¹ it's virtually invisible. TruScene insect screens are made with a micro-fine stainless steel mesh that's one-third the diameter of standard screen wire² to let more fresh air and sunlight in, while keeping most of the smallest insects out.

Lets more light in Superior ventilation Patented technology Protection against some of the smallest insects



Wood-Veneered TruScene® Insect Screen

Our wood veneered TruScene® insect screen blends seamlessly into the window frame and can be stained or painted to match your decor. Available on casement and awning windows only.

Keeps out most bugs



Conventional

Fiberglass Insect Screen

Fiberglass is the most common type of insect screen. It is strong and keeps the majority of bugs out while allowing plenty of air flow.

Aluminum Insect Screen

Our aluminum insect screen has a charcoal powder coating to reduce glare and increase visibility. It is also strong, and has good ventilation and corrosion resistance.

Hardware Finish options

Sophistication...a whisper of style and confidence.

Define Your Style

Not only does Renewal by Andersen hardware function well, but its metal construction is also long-lasting! With multiple color options, you can match your home's existing colors or change the look by choosing a new color that complements your new windows.

With so many design options, you can create the windows you've always wanted with the design features that are right for you and your home.

Do you want to make your mark? With our Estate® Hardware metal finishes, explore the many creative possibilities sure to add charm to your home that others will notice!

EXCLUSIVE FEATURE



Polished Chrome



Brushed Chrome



Satin Nickel



Distressed Nickel



Bright Brass



Antique Brass



Distressed Bronze



Oil Rubbed Bronze

Estate Hardware

ESTATE HARDWARE

Standard Hardware



White



Canvas



Stone



Dark Bronze

Nesting handles reduce interference with window treatments



Estate® Double-Hung Hand Lift / Bright Brass Finish



Estate® Casement and Awning Window Hands / Antique Brass Finish



Estate® Casement Window Latch / Antique Brass Finish



Estate® Birding Window Latch / Distressed Nickel Finish



Estate® Double-Hung Finger Lift / Bright Brass Finish



Estate® Double-Hung Window Latch / Satin Nickel Finish



Estate® Double-Hung Window Latch / White Finish

Frenchwood® GLIDING PATIO DOORS

The same familiar style and exceptional features of our French doors are also available in a compact, space-saving design that glides like a dream. Choose stainable oak, maple, pine or unfinished white interior to complement your home.

APPEALING

French door design in a space-saving gliding door format.

PROTECTED

Frame is covered with a rigid vinyl sheath for an attractive appearance with minimal maintenance.

EASY

Door easily slides open on Andersen's track rollers.

SECURE

Reach-out lock system provides increased security.

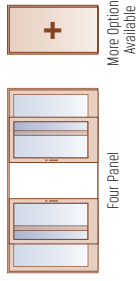
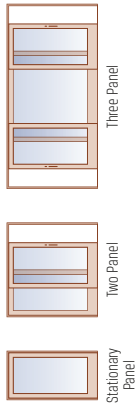

UPPER YOUR STYLE

Color Options²

INTERIOR

- Real Maple
- Real Pine
- Real Oak
- Real Pine
- Perfinished White¹¹

EXTERIOR

- White
- Canvas⁸
- Sandstone
- Terratone
- Black⁹
- Dark Bronze⁶
- Black¹⁰
- Forest Green
- Red Rock⁷
- Cocoa Bean⁴



Frenchwood® Gliding Patio Door / Pine Interior



Frenchwood® Gliding Patio Door / White Interior / Short Fractional Grilles

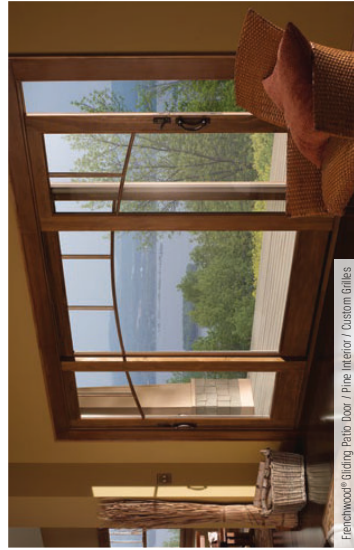

Frenchwood® Gliding Patio Door / Pine Interior / Custom Grilles



Narroline® Gliding Patio Door / Pine Interior



Narroline® Gliding Patio Door / White Exterior

Narroline® GLIDING PATIO DOORS

The sleek, modern design of our contemporary gliding patio doors features thin frames for maximum glass area and doors that slide smoothly on Andersen's dual ball-bearing rollers with self-contained leveling adjusters. A reach-out lock system provides increased security and weather-tightness you can see in action.

SIMPLE

Stainable natural pine interior with mortise-and-tenon joints.

DURABLE

Exterior wood door panel is protected with a urethane-based finish.



Stationary Panel



Two Panel



Four Panel



More Options Available

UPPER YOUR STYLE

Color Options²

INTERIOR

- Real Pine
- White
- Canvas
- Dark Bronze
- Sandstone
- Terratone
- Black

Patio Door Engineering

A combination of details not found elsewhere.

FUNCTIONAL REQUIREMENTS:

- Performance Grade LC (Light Commercial) water and air leakage resistance

ENGINEERING SOLUTION:

- Weatherstrip airtight system

HOMEOWNER BENEFIT:

Patio doors with a higher performance grade than other residential patio doors.



FUNCTIONAL REQUIREMENTS:

- Reduce water infiltration during extreme weather events

ENGINEERING SOLUTION:

- Gasket and drain sill (Frenchwood® Patio Doors only)

HOMEOWNER BENEFIT:

Rare water infiltration, even in the worst storms, because excess water is contained, then drained away from the house.



STANDARD FEATURE



Gliding Patio Door Locks

The unique Andersen® reach-out locking system pulls the door panel snugly into the jamb for weather-tightness and enhanced security.

FUNCTIONAL REQUIREMENTS:

- Door operation

ENGINEERING SOLUTION:

- Ball bearing track rollers

HOMEOWNER BENEFIT:

A gliding door that glides reliably and has superior weathertightness.



FUNCTIONAL REQUIREMENTS:

- Strengthen corner joints
- Increase patio door beauty

ENGINEERING SOLUTION:

- Mortise-and-tenon corner joint

HOMEOWNER BENEFIT:

Unique corner key design increases structural integrity and beauty.



STANDARD FEATURE



Hinged Patio Door Locks

Five-point locking system improves energy efficiency and offers an increased level of security. Also available is an optional handle extension kit which creates additional clearance for interior blinds and shades.

Patio Door OPTIONS

Create curb appeal or architecturally accurate styling.

Grilles



Colonial

Specific number of squares per sash.

Frenchwood® hinged patio door shown

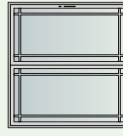

Prairie

Two vertical and two horizontal bars per sash to form 4 inch corner squares.

Harvest® gliding patio door shown

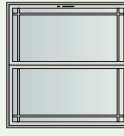

Modified Prairie

Two horizontal bars and one vertical bar per sash.

Harvest® gliding patio door shown



Tall Fractional

Specific number of vertical bars and one horizontal bar.

Frenchwood® gliding patio door shown

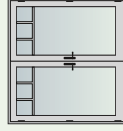

Short Fractional

Specific number of vertical bars and one horizontal bar.

Frenchwood® hinged patio door shown

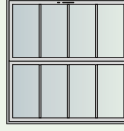

Equal Light

Specified number of horizontal bars, equal distance apart.

Harvest® gliding patio door shown

YOUR STYLE

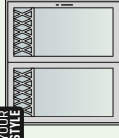

Custom

Create a new pattern or revive one from the past.

Frenchwood® gliding patio door shown

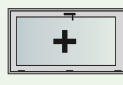

More

Ask your replacement consultant for more grille options.

Frenchwood® hinged patio door shown

Insect Screens

Hinged, double-hinged, gliding and retractable insect screens are options for your Andersen® patio doors, and are available in an exterior color to match your patio door.



Hinged Insect Screen

COMPATIBLE WITH: Frenchwood® hinged patio doors (one panel)



Gliding Insect Screen

COMPATIBLE WITH: Frenchwood® hinged patio doors (two panel) All gliding patio doors



Double-Hinged Insect Screen

COMPATIBLE WITH: Frenchwood® hinged patio doors (two panel)



Retractable Insect Screen

COMPATIBLE WITH: Frenchwood® hinged outswinging patio doors^{1,4} All gliding patio doors

Security



Exterior Keyed Locks

COMPATIBLE WITH: All patio doors



Auxiliary Foot Lock

Offers an extra measure of security when the door is in the locked position. It can also hold the operating panel partially open.

COMPATIBLE WITH: Gliding patio doors only

Patio Door Security

STANDARD FEATURE



Gliding Patio Door Locks

The unique Andersen® reach-out locking system pulls the door panel snugly into the jamb for weather-tightness and enhanced security.

STANDARD FEATURE



Hinged Patio Door Locks

Five-point locking system improves energy efficiency and offers an increased level of security. Also available is an optional handle extension kit which creates additional clearance for interior blinds and shades.

Glass options

All the Right Rays

Each Renewal by Andersen® glass option offers four unique benefits for heating, cooling, visible light transfer, and ultraviolet (UV) protection. The glass solution for you depends on the climate you live in, the architectural design of your home, and the orientation of your windows to the sun.

A Revolutionary Sash Design

Renewal by Andersen's combination of high standards in engineering and exclusive materials are critical components for energy efficiency and long-term performance. Our glass constructions are certified for durability by the world's leading organizations for the engineering and manufacturing of insulating glass.

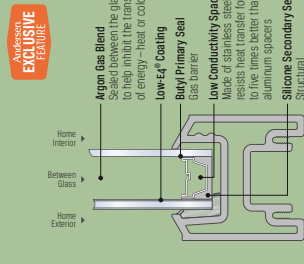

Andersen EXCLUSIVE FEATURE

Maximize your energy savings.

Performance



HIGH-PERFORMANCE Low-E4® SmartSun™ Glass

SmartSun™ glass is our most energy efficient glass option. It has the highest efficiency rating in cool weather and is exceptional in hot climates where solar heat gain can lead to excessive air conditioning expense. SmartSun™ glass lets in almost as much natural daylight as clear glass.

45% more energy-efficient in winter¹⁵

70% more energy-efficient in summer¹⁵

Blocks 95% of UV rays that can damage drapes, artwork and furniture



HIGH-PERFORMANCE Low-E4® Glass

Helps to keep your home warmer in winter, cooler in summer and filters most ultraviolet rays. Outstanding overall performance in climates where both heating and cooling costs are a concern.

45% more energy-efficient in winter¹⁵

56% more efficient in summer¹⁵

Blocks 84% of harmful UV rays



HIGH-PERFORMANCE Low-E4® SmartSun™ Glass with HeatLock™ Technology

Meets today's most stringent energy codes and requirements.

The newest glass technology

Reflects escaping heat back into the room

Makes your living space feel warmer



HIGH-PERFORMANCE Low-E4® Sun Glass

Sun glass has our highest rating against solar heat gain coming through your window to help keep your home cooler in warm weather. A tint coating reduces the amount of visible light and sunshine streaming in from the outside.

Includes a tint coating to reduce visible light

Highest rating against solar heat gain

Keeps your home cooler in warm weather

Patterns

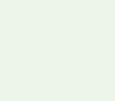

Obscure

Fern

Reed¹⁶

Cascade¹⁶

Strength

Our tempered glass option is heat-treated to be at least four times stronger than regular glass.

¹⁵ Values are based on comparison of Renewal by Andersen double-hung paired window spec to the spec for clear dual-pane glass non-metal frame default values from the 2006 and 2009 International Energy Conservation Code. ¹⁶ Glass available in the home exterior surface and can be (RE).

Your Design:

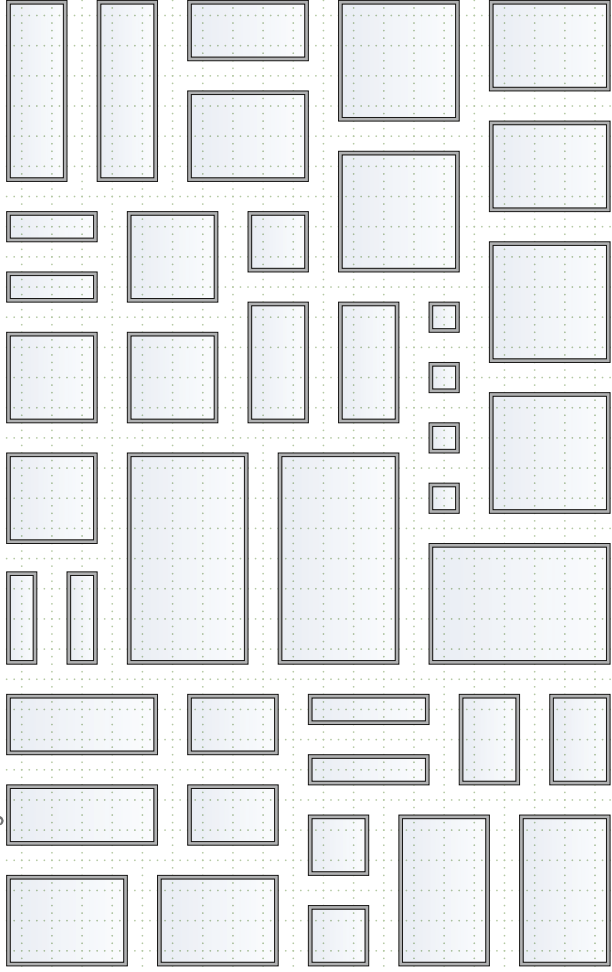

Your Window Replacement Consultant will help you along every step of your project by...

- ...listening to your needs
- ...providing solutions that may add value to your home
- ...helping you determine the best style for your home
- ...communicating your project's progress
- ...saving you time and stress



Industry-Leading Warranty



We stand behind our products and services.

The Renewal by Andersen limited warranty is one of the strongest you'll find on any window or door, at any price. It's non-prorated and fully transferable. Every window we make is labeled with our toll-free number, should you have any issues with your window. It's one more way that you know we're here for you now and well into the future.

Your satisfaction is our measure for success.

Nationwide, a homeowner satisfaction survey is sent to each home after every project we do. Customer satisfaction is a primary component of the Renewal by Andersen culture. Your feedback has proven to be an invaluable asset as we continue our never ending mission to improve our products and services.

Call us today.

We would love to help you with your replacement project.

Window and Door Replacement from a Company You Can Trust®

Don't just take our word for it. Renewal by Andersen has long been committed to environmentally responsible products and manufacturing methods. Our efforts have been recognized by leading organizations with some of the most rigorous standards in the United States.



Morton, Erin

From: Sean Thomas <sthomas@pelladirect.com>
Sent: Monday, August 24, 2020 2:22 PM
To: Morton, Erin
Cc: Tully, Tania; Kinane, Collette; Dan Chaksupa
Subject: RE: COA-0105-2020 (616 N Boundary St) Minor Work
Attachments: Architect Series, Jam Details 2020.jpg

CAUTION: This email originated from outside of the organization. Do not click links or open attachments unless you verify that the attachment and content are safe. If you believe this email is suspicious, please click the 'Phish Alert' link in the banner to report this message.

Erin,

My apologies. Please see attachment.

Best,

Sean Thomas
Replacement Sales Consultant



T: 919-859-9881
M: 919-622-6490
Pella Carolina Inc. - 8831 Westgate Park Dr Suite 104 Raleigh, NC 27617
sthomas@pelladirect.com - www.pellanorthcarolina.com



CONFIDENTIALITY NOTICE: This email message, including any attachments, is for the sole use of the intended recipient(s) and may contain confidential and privileged information. Any unauthorized review, use, disclosure or distribution is prohibited. If you are not the intended recipient, please contact the sender by reply email and destroy all copies of the original message. Please note that while we scan all emails for viruses, we cannot guarantee that any email is virus-free

From: Morton, Erin <Erin.Morton@raleighnc.gov>
Sent: Monday, August 24, 2020 2:00 PM
To: Sean Thomas <sthomas@pelladirect.com>
Cc: Tully, Tania <Tania.Tully@raleighnc.gov>; Kinane, Collette <Collette.Kinane@raleighnc.gov>; Dan Chaksupa <dchaksupa@yahoo.com>
Subject: COA-0105-2020 (616 N Boundary St) Minor Work

Sean,

The below graphic appears to contain the information we need to see, but is pixelated to the point of illegibility. If this is an all-wood window and you can provide a high quality image (please attach rather than embedded in the email), we are able to provide approval. We look forward to hearing from you. Thank you.

Best,
Erin

Morton, Erin

From: Sean Thomas <sthomas@pelladirect.com>
Sent: Monday, August 24, 2020 2:08 PM
To: Morton, Erin
Cc: Tully, Tania; Kinane, Collette; Dan Chaksupa
Subject: Re: COA-0105-2020 (616 N Boundary St) Minor Work

CAUTION: This email originated from outside of the organization. Do not click links or open attachments unless you verify that the attachment and content are safe. If you believe this email is suspicious, please click the 'Phish Alert' link in the banner to report this message.

Erin,

Please see below and let me know if you're able to see what's needed.

Best,

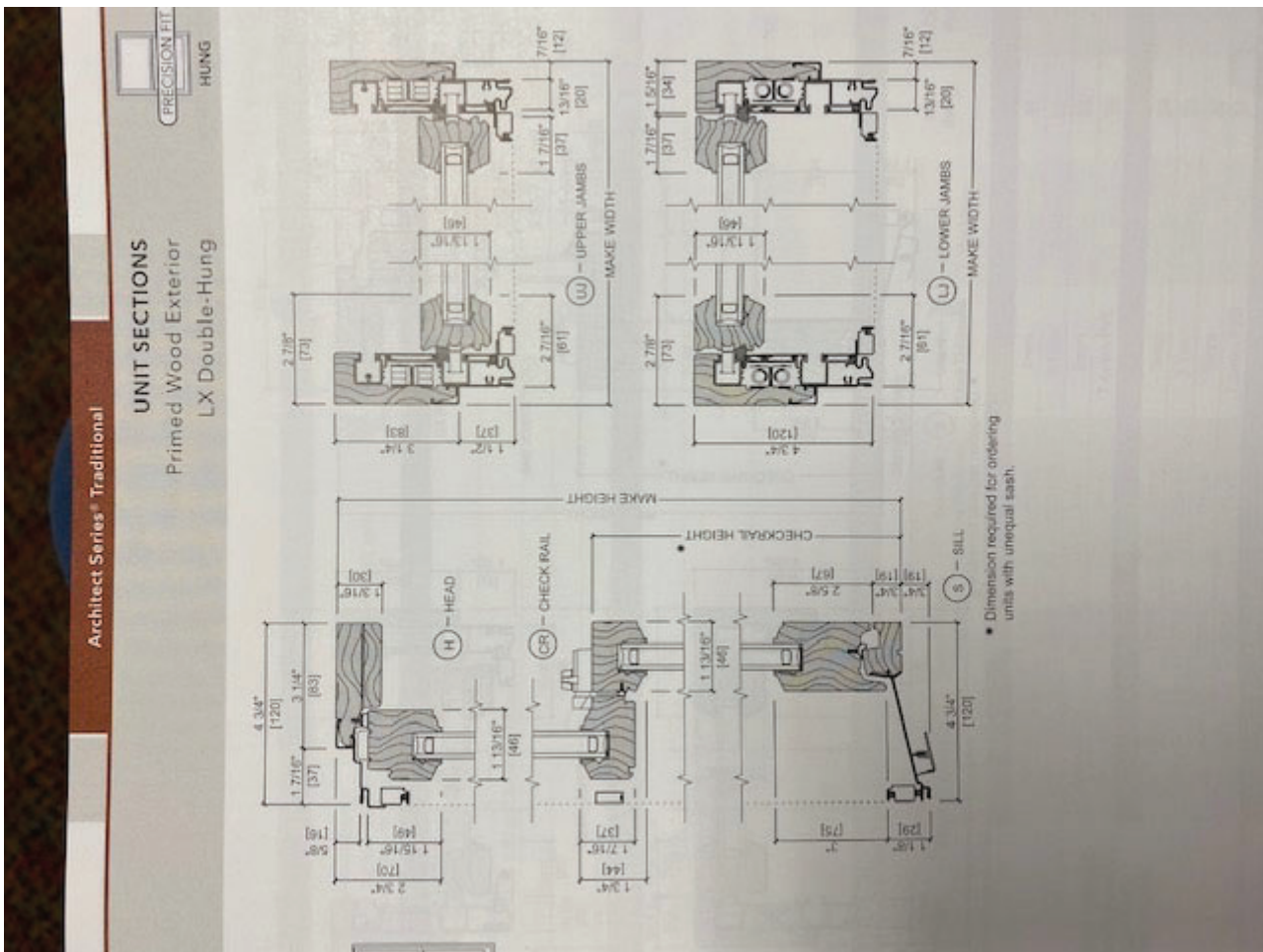

Sent from my iPhone

Sean Thomas
Replacement Sales Consultant



T: 919-859-9881
M: 919-622-6490
Pella Carolina Inc. - 8831 Westgate Park Dr Suite 104 Raleigh, NC 27617
sthomas@pelladirect.com - www.pellanorthcarolina.com



CONFIDENTIALITY NOTICE: This email message, including any attachments, is for the sole use of the intended recipient(s) and may contain confidential and privileged information. Any unauthorized review, use, disclosure or distribution is prohibited. If you are not the intended recipient, please contact the sender by reply email and destroy all copies of the original message. Please note that while we scan all emails for viruses, we cannot guarantee that any email is virus-free

On Aug 24, 2020, at 1:59 PM, Morton, Erin <Erin.Morton@raleighnc.gov> wrote:

Sean,

The below graphic appears to contain the information we need to see, but is pixelated to the point of illegibility. If this is an all-wood window and you can provide a high quality image (please attach rather than embedded in the email), we are able to provide approval. We look forward to hearing from you. Thank you.

Best,
Erin

Erin Morton

Preservation Planner II

City of Raleigh

Planning and Development

■ Raleigh Urban Design Center

919-996-2632 | raleighnc.gov

For Planning and Development COVID-19 updates, [visit our information page.](#)

From: Sean Thomas <sthomas@pelladirect.com>
Sent: Friday, August 21, 2020 5:06 PM
To: Morton, Erin <Erin.Morton@raleighnc.gov>
Subject: Re: Dan Chapsuka 616 N. Boundary - Minor Work

CAUTION: This email originated from outside of the organization. Do not click links or open attachments unless you verify that the attachment and content are safe. If you believe this email is suspicious, please click the 'Phish Alert' link in the banner to report this message.

Erin,

Please see below.

<image001.png>
Sent from my iPhone

Sean Thomas | Replacement Sales Consultant | T: [919-859-9881](tel:919-859-9881) | M: [919-622-6490](tel:919-622-6490) |
sthomas@pelladirect.com | www.pellanorthcarolina.com

On Aug 21, 2020, at 4:16 PM, Morton, Erin <Erin.Morton@raleighnc.gov> wrote:

Hi Sean,

I see at the link provided that Pella has all wood window options available, but I do not see window section details for the wood window. Please provide a PDF of the head, jamb, and sill section details for the exact product to be installed. It would be extremely helpful if all the potential options are not included, but rather simple section details of the actual window to be installed. We need to be able to reference our files for questions from future applicants and know exactly what was approved and installed. Your assistance with clarifying that information so that the application may move forward is greatly appreciated. Thank you.

Best,
Erin

Erin Morton

Preservation Planner II

City of Raleigh

Planning and Development

■ Raleigh Urban Design Center

919-996-2632 | raleighnc.gov

For Planning and Development COVID-19 updates, [visit our information page.](#)

From: Sean Thomas <sthomas@pelladirect.com>

Sent: Friday, August 21, 2020 3:27 PM

To: Morton, Erin <Erin.Morton@raleighnc.gov>

Cc: Dan Chaksupa <dchaksupa@yahoo.com>; Tully, Tania <Tania.Tully@raleighnc.gov>;
Kinane, Collette <Collette.Kinane@raleighnc.gov>

Subject: RE: Dan Chapsuka 616 N. Boundary - Minor Work

CAUTION: This email originated from outside of the organization. Do not click links or open attachments unless you verify that the attachment and content are safe. If you believe this email is suspicious, please click the 'Phish Alert' link in the banner to report this message.

Erin,

Please see the link below. This will have anything you need.

<https://professional.pella.com/windows/product-details/hung-architect-reserve>

Sean Thomas | Replacement Sales Consultant | T: [919-859-9881](tel:919-859-9881) | M: [919-622-6490](tel:919-622-6490) | sthomas@pelladirect.com | www.pellanorthcarolina.com

From: Morton, Erin <Erin.Morton@raleighnc.gov>
Sent: Friday, August 21, 2020 12:54 PM
To: Sean Thomas <sthomas@pelladirect.com>
Cc: Dan Chaksupa <dchaksupa@yahoo.com>; Tully, Tania <Tania.Tully@raleighnc.gov>; Kinane, Collette <Collette.Kinane@raleighnc.gov>
Subject: RE: Dan Chapsuka 616 N. Boundary - Minor Work

Sean,

That is great to learn that Pella offers an all-wood option. Please see attached for an example of the window section information we need in order to consider the application complete. This information should be to the specific window that is proposed to be installed in the existing opening. Let us know if you have any questions. Thank you.

Best,
Erin

Erin Morton

Preservation Planner II

City of Raleigh

Planning and Development

■ Raleigh Urban Design Center

919-996-2632 | raleighnc.gov

For Planning and Development COVID-19 updates, [visit our information page](#).

From: Sean Thomas <sthomas@pelladirect.com>
Sent: Friday, August 21, 2020 12:35 PM
To: Morton, Erin <Erin.Morton@raleighnc.gov>
Cc: Dan Chaksupa <dchaksupa@yahoo.com>; Tully, Tania <Tania.Tully@raleighnc.gov>
Subject: RE: Dan Chapsuka 616 N. Boundary - Minor Work

CAUTION: This email originated from outside of the organization. Do not click links or open attachments unless you verify that the attachment and content are safe. If you believe this email is suspicious, please click the 'Phish Alert' link in the banner to report this message.

Erin,

Please see the below attributes for the Pella Architect Series window we've proposed for Mr. Chapsuka. While the default for this window is a clad jamb, we have full capabilities to customize this product line. If you'll notice below, I've highlighted the exterior jamb section in question to reflect that it will indeed be primed wood.

Feel free to contact me directly should you need any additional information.

Sean Thomas
Replacement Sales Consultant

T: 919-859-9881
M: 919-622-6490
Pella Carolina Inc. - 8831 Westgate Park Dr Suite 104 Raleigh, NC 27617
sthomas@pelladirect.com - www.pellanorthcarolina.com

<image001.jpg>

<image007.png>

<image008.png>

<image009.png>

CONFIDENTIALITY NOTICE: This email message, including any attachments, is for the sole use of the intended recipient(s) and may contain confidential and privileged information. Any unauthorized review, use, disclosure or distribution is prohibited. If you are not the intended recipient, please contact the sender by reply email and destroy all copies of the original message. Please note that while we scan all emails for viruses, we cannot guarantee that any email is virus-free

From: Sean Thomas <loujack71@gmail.com>
Sent: Friday, August 21, 2020 12:24 PM
To: Sean Thomas <sthomas@pelladirect.com>
Subject: <External>

<image010.jpg>

Sent from my iPhone

Morton, Erin

From: Morton, Erin
Sent: Friday, August 21, 2020 11:02 AM
To: dan chaksupa
Cc: Tully, Tania; Kinane, Collette
Subject: RE: COA-0105-2020 (616 N Boundary Street) Minor Work

Dan,

Thank you for the photos and the additional window information. We are still looking for the scaled window sections details, including header, jamb, and sill profiles. We provided an example of the standard sections in a previous email dated to 07/21/20. I see in the most recent window attachment that there is a jamb section detail for the double-hung windows, but this appears to be a wood clad window detail, rather than all wood. Staff is only able to approve all wood windows at the minor work level.

In a quick look at the Pella website, it appears that the PDF links to the information we need are not working. You will probably need to contact the supplier from whom you are purchasing the window or explore other manufacturers. Lincoln, Sierra Pacific, and JELD-WEN are manufacturers we frequently see in COA applications. Please let us know if you have additional questions about the requested information. Thank you and hope you have a good weekend.

Best,
Erin

Erin Morton

Preservation Planner II

City of Raleigh

Planning and Development
■ Raleigh Urban Design Center
919-996-2632 | raleighnc.gov

For Planning and Development COVID-19 updates, [visit our information page.](#)

From: dan chaksupa <dchaksupa@yahoo.com>
Sent: Friday, August 14, 2020 2:00 PM
To: Morton, Erin <Erin.Morton@raleighnc.gov>
Subject: Re: COA-0105-2020 (616 N Boundary Street) Minor Work

CAUTION: This email originated from outside of the organization. Do not click links or open attachments unless you verify that the attachment and content are safe. If you believe this email is suspicious, please click the 'Phish Alert' link in the banner to report this message.

erin,

i am submitting an elevation diagram as well as the photos of the front of the home and the window that is to be replaced (the window would be on the right side of the house if you are looking at the front of the house), thanks!

dan

On Wednesday, July 22, 2020, 01:31:42 PM EDT, Morton, Erin <erin.morton@raleighnc.gov> wrote:

Dan,

Thanks for the meeting today – I hope our conversation cleared up your questions. As discussed, I have included a short list of window manufacturers with all-wood production lines that have been approved through other COAs in the past few months. Note that not every window product produced by these manufacturers meets the requirements. This is not a complete list and as public employees, we are not endorsing any particular all-wood product over another. This is just meant to give you a starting point.

Lincoln

Sierra Pacific

JELD-WEN

Marvin

Please do resend the photograph attachments, as they do not appear to have come through on our end. We look forward to receiving the window section information whenever you are able to make a selection. Please let us know if you have any other questions. Thank you!

Best,

Erin

Erin Morton

Preservation Planner II

City of Raleigh

Planning and Development

■ Raleigh Urban Design Center

For Planning and Development COVID-19 updates, [visit our information page.](#)

From: Morton, Erin
Sent: Wednesday, July 22, 2020 11:24 AM
To: Dan Chaksupa <dchaksupa@yahoo.com>
Cc: Tully, Tania <Tania.Tully@raleighnc.gov>; Kinane, Collette <Collette.Kinane@raleighnc.gov>
Subject: RE: COA-0105-2020 (616 N Boundary Street) Minor Work

Dan,

You should have a Webex meeting invite from me in your inbox. Please let me know if you do not receive it. Looking forward to speaking with you at 1:00 PM.

Best,
Erin

Erin Morton

Preservation Planner II

City of Raleigh

Planning and Development

■ Raleigh Urban Design Center

919-996-2632 | raleighnc.gov

For Planning and Development COVID-19 updates, [visit our information page.](#)

From: Dan Chaksupa <dchaksupa@yahoo.com>
Sent: Wednesday, July 22, 2020 10:49 AM
To: Morton, Erin <Erin.Morton@raleighnc.gov>
Subject: Re: COA-0105-2020 (616 N Boundary Street) Minor Work

CAUTION: This email originated from outside of the organization. Do not click links or open attachments unless you verify that the attachment and content are safe. If you believe this email is suspicious, please click the 'Phish Alert' link in the banner to report this message.

could we schedule it today at 1p? thanks

dan

On Jul 22, 2020, at 09:53, Morton, Erin <Erin.Morton@raleighnc.gov> wrote:

Dan,

Sure, I can set up a Webex video call and send you an invite. I am available this afternoon or tomorrow before 1:00 PM. Is there a time that works best for you?

Best,

Erin

Erin Morton

Preservation Planner II

City of Raleigh

Planning and Development

■ Raleigh Urban Design Center

919-996-2632 | raleighnc.gov

For Planning and Development COVID-19 updates, [visit our information page.](#)

From: dan chaksupa <dchaksupa@yahoo.com>
Sent: Tuesday, July 21, 2020 7:09 PM
To: Morton, Erin <Erin.Morton@raleighnc.gov>
Subject: Re: COA-0105-2020 (616 N Boundary Street) Minor Work

CAUTION: This email originated from outside of the organization. Do not click links or open attachments unless you verify that the attachment and content are safe. If you believe this email is suspicious, please click the 'Phish Alert' link in the banner to report this message.

there are certain parts of your previous email about i did not understand-would you be able to take a call to help clarify and answer my questions?

dan

On Tuesday, July 21, 2020, 04:25:23 PM EDT, Morton, Erin <erin.morton@raleighnc.gov> wrote:

Hey Dan,

Staff is only able to approve all-wood windows via the minor work process. A wood or painted cellular PVC sill is also approvable at the staff level. It appears that you are proposing a composite material window. I apologize for not pointing this out in previous emails. If you would like to pursue the request for a composite material window, we can convert the application to a major work COA for review by the RHDC's COA Committee. The Committee has not yet approved a non-wood window in a historic house. It should also be noted that we are currently catching up on cases due to March and April meeting COVID-related cancellations; your application will likely not be heard until the September COA meeting. Please let us know if you would like to pursue this option.

If you are comfortable with providing a wood one-over-one window, please provide a section detail drawing to show the proposed window profile. I have attached an example of what this looks like. Again, the manufacturer should be able to provide this to you. Please also provide a photo of the full window (the top of the window is cut off in the materials we have), as well as a general photo of the full front façade of the house.

Please let us know how you would like to proceed and whether you have any questions. Thank you.

Best,

Erin

Erin Morton

Preservation Planner II

City of Raleigh

Planning and Development

■ Raleigh Urban Design Center

919-996-2632 | raleighnc.gov

For Planning and Development COVID-19 updates, [visit our information page.](#)

From: dan chaksupa <dchaksupa@yahoo.com>
Sent: Tuesday, July 21, 2020 8:50 AM
To: Morton, Erin <Erin.Morton@raleighnc.gov>
Subject: Re: COA-0105-2020 (616 N Boundary Street) Minor Work

CAUTION: This email originated from outside of the organization. Do not click links or open attachments unless you verify that the attachment and content are safe. If you believe this email is suspicious, please click the 'Phish Alert' link in the banner to report this message.

erin,

i have reattached the COA application along with additional photos as requested. i have also attached the manufacturer catalogue that has an illustration of the double hung window (page 7). finally, only the window and sill will be replaced, not the exterior frame. please let me know if you have any questions, thanks!

dan

On Monday, July 20, 2020, 12:22:12 PM EDT, Morton, Erin <erin.morton@raleighnc.gov> wrote:

Hi Dan,

Thank you for following up with an email, as that is definitely the quickest way to get ahold of us while most of the department is working remotely. We only need you to re-submit the two-page application form itself – for some reason, the fillable-field PDF comes through blank for some applicants if the print to PDF/file name change method is not used.

You can email all new materials directly to me. We will upload a final packet to the portal including all application materials when we issue the placard as well. Thank you and let us know if you have any other questions.

Best,

Erin

Erin Morton

Preservation Planner II

City of Raleigh

Planning and Development

■ Raleigh Urban Design Center

919-996-2632 | raleighnc.gov

For Planning and Development COVID-19 updates, [visit our information page.](#)

From: Dan Chaksupa <dchaksupa@yahoo.com>
Sent: Monday, July 20, 2020 11:53 AM
To: Morton, Erin <Erin.Morton@raleighnc.gov>
Subject: Re: COA-0105-2020 (616 N Boundary Street) Minor Work

CAUTION: This email originated from outside of the organization. Do not click links or open attachments unless you verify that the attachment and content are safe. If you believe this email is suspicious, please click the 'Phish Alert' link in the banner to report this message.

Erin,

I just left you a message on your office phone-do you need me to upload all files in my application or just a specific file? And do you need me to upload them to the portal or to email them directly to you? Thanks!

Dan

On Jul 17, 2020, at 15:03, Morton, Erin <Erin.Morton@raleighnc.gov> wrote:

Hi Dan,

Thank you for submitting your minor work application for 616 N Boundary Street. We have conducted a review of your application and have the following comments for you. For some reason, the application you have uploaded is blank; can you try printing to PDF and/or changing the name of the file and resending? Will you be replacing the window sill and frame as well as the double-hung sash?

Please provide a photo of the full front of the house and a photo of the window unit to be replaced – the top of the window unit is cut off in the photo provided. Replacing the one-over-one window with a new one-over-one window is fine. Please also provide a window section drawing for the proposed replacement product. This should be readily available from the manufacturer.

Please provide the additional information as you are able in order for us to complete the review. Thank you and have a good weekend!

Best,

Erin

Erin Morton

Preservation Planner II

City of Raleigh

Planning and Development

■ Raleigh Urban Design Center

919-996-2632 | raleighnc.gov

For Planning and Development COVID-19 updates, [visit our information page.](#)

<image001.jpg>

<image002.jpg>