

### PAVEMENT SCHEDULE

C1	2" ASPHALT CONCRETE SURFACE COURSE, TYPE S9.5B, AT AN AVERAGE RATE OF 220 LBS. PER SQ. YD. OR 110 LBS. PER SQ. YD. IN EACH OF TWO LAYERS
J1	6" AGGREGATE BASE COURSE
R1	CURB AND GUTTER
T	EARTH MATERIAL
V1	GEOTEXTILE FOR PAVEMENT STABILIZATION

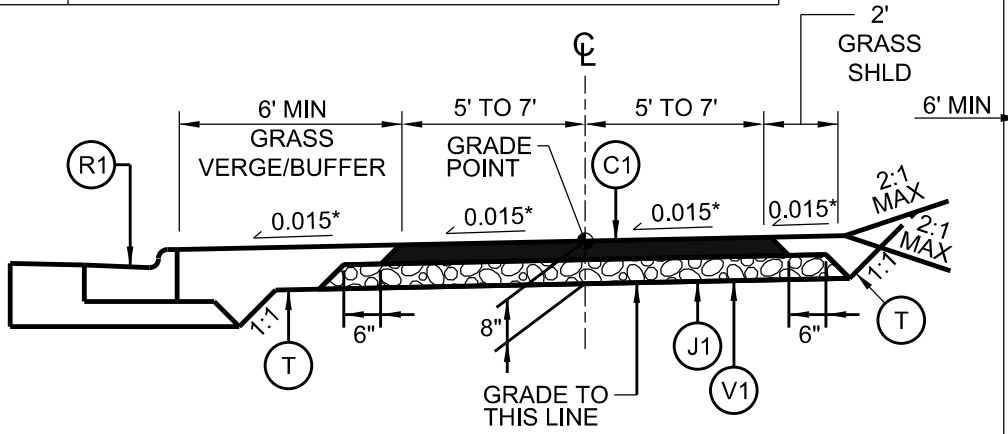

### CROSS-SECTION VIEW

\* 0.02 MAX

# ASPHALT MULTI-USE STREET SIDE TRAIL, VARIABLE WIDTH

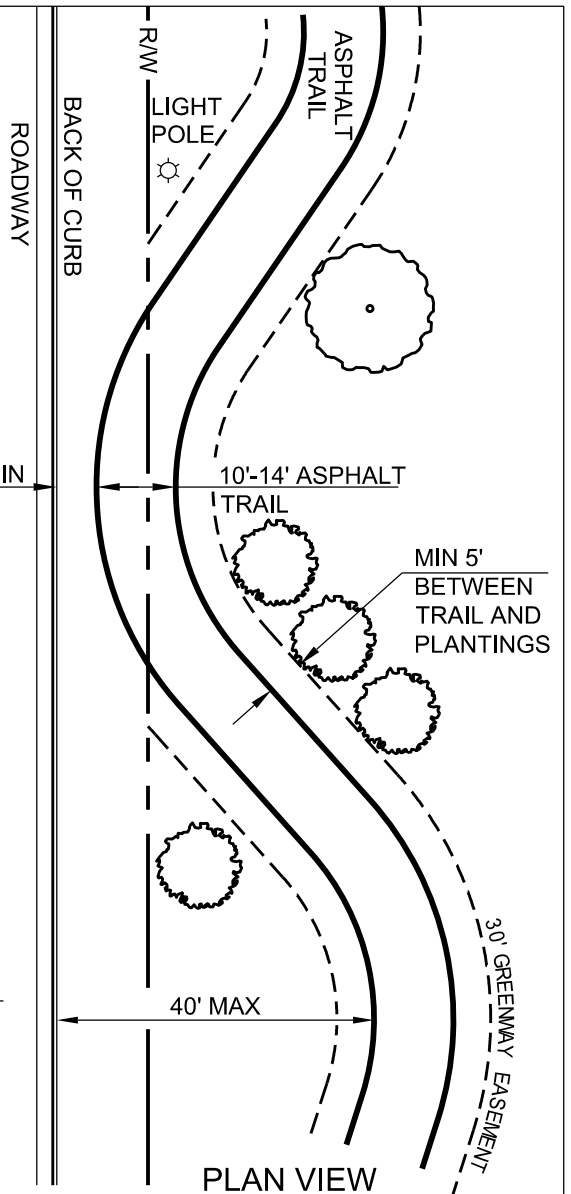

### PLAN VIEW

### NOTES:

1. TRAIL WIDTH TO BE DETERMINED BY CITY OF RALEIGH. 10 FEET MINIMUM TRAIL WIDTH IS NECESSARY FOR BICYCLISTS TO PASS OTHER USERS SAFELY ON SIDE TRAILS.
2. TRAILS CAN MEANDER BUT SHALL BE LOCATED MINIMUM 6 FEET FROM THE BACK OF CURB. NCDOT WILL ALLOW A 3-FOOT VEGETATED BUFFER INSTEAD OF 6-FOOT UNDER CERTAIN CONDITIONS WHERE ROW IS CONSTRAINED. SPECIAL PERMISSION MUST BE GRANTED.
3. IDEALLY, NO ABOVE-GROUND UTILITIES OR UTILITY SURFACE COVERS/PLATES/MANHOLES SHALL BE LOCATED WITHIN THE TRAIL AND SHALL BE A MINIMUM OF 2 FEET FROM THE EDGE OF TRAIL. RAISED MANHOLES SHALL BE A MINIMUM OF 4 FEET FROM THE EDGE OF TRAIL.
4. TRAIL RUNNING SLOPES/VERTICAL GRADE SHALL NOT EXCEED THE VERTICAL GRADE OF THE ROADWAY.
5. 1.5% (2.08% OR 1:48 MAX) CROSS SLOPE. CROSS SLOPE DIRECTION TYPICALLY SLOPES TOWARD ROADWAY BUT CAN VARY. SLOPE SHOULDERS FOR POSITIVE DRAINAGE. OFTEN REQUIRES CONTINUING PAVEMENT OR SHOULDER SLOPE UNTIL TIE-IN WITH NATURAL GROUND. SEE PLAN SHEETS AND CROSS SECTIONS.
6. WHEN CONDITIONS PERMIT, SHOULDERS TO MATCH CROSS SLOPE OF TRAIL AND SIDE SLOPES TO BE 3:1 OR FLATTER.
7. CONTRACTOR IS RESPONSIBLE FOR RE-ESTABLISHING ALL SLOPES DISTURBED DURING CONSTRUCTION.
8. PROOF ROLLING SHALL OCCUR IN PRESENCE OF OWNER OR OWNER'S TESTING AGENCY AT THE FOLLOWING STAGES: 1) PRIOR TO PLACING FILL IN LOW AREAS; 2) AFTER PREPARING SUBGRADE PRIOR TO PLACING ABC; 3) AFTER PLACEMENT OF ABC PRIOR TO PAVING.
9. PAVEMENT EDGE SLOPES ARE 1:1 UNLESS OTHERWISE NOTED.
10. UNDER SOME CIRCUMSTANCES, SIDE TRAILS MAY TRANSITION TO SIDEWALKS AND DESIGNATED BICYCLE LANES. IN THE EVENT THAT SIDE TRAILS MERGE ONTO STREETS, PROVIDE APPROPRIATE SIGNAGE AND PAVEMENT MARKINGS TO HELP SAFE MERGING.
11. ALL TRAILS WITHIN NCDOT ROADWAY ROW MUST CONSIDER THE FOLLOWING:
  - NCDOT REQUIRES AN ENCROACHMENT PERMIT FROM NCDOT.
  - STRUCTURES, SUCH AS RETAINING WALLS AND BRIDGES, ARE TYPICALLY NOT PERMITTED IN NCDOT ROW AND MAY ONLY BE USED IN SPECIAL CONDITIONS.
  - NCDOT MAY REQUIRE A CLEAR RECOVERY ZONE OF 11.5 FEET TO 24 FEET (IN THE PRESENCE OF A DITCH SECTION) FROM THE EDGE OF TRAVEL LANE TO EDGE OF GREENWAY TRAIL DEPENDING ON AVERAGE DAILY TRAFFIC (ADT) AND DESIGN SPEEDS.
  - STORMWATER TREATMENT AND VEG. MUST BE INSTALLED PER NCDOT'S SPECS.

<b>CITY OF RALEIGH STANDARD DETAIL</b>		
REVISIONS	DATE: 12/2022	NOT TO SCALE
	ASPHALT MULTI-USE STREET SIDE TRAIL, VARIABLE WIDTH	
	<b>GW-10.10</b>	