

DRIVEWAY GRADES

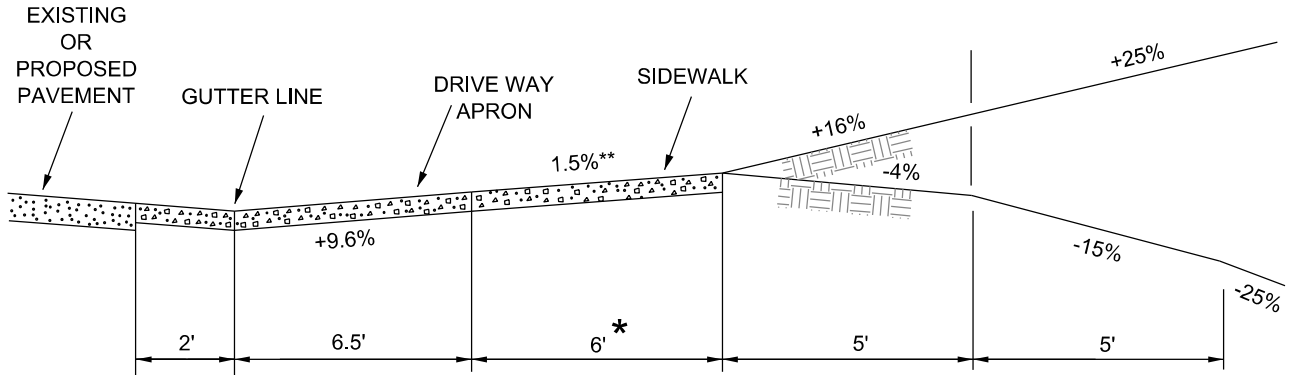

* 5' FOR SENSITIVE AREA AVENUE
AND SENSITIVE AREA RESIDENTIAL STREET

** 2.08% (1:48) max

A. CURB & GUTTER , SIDEWALK SECTION

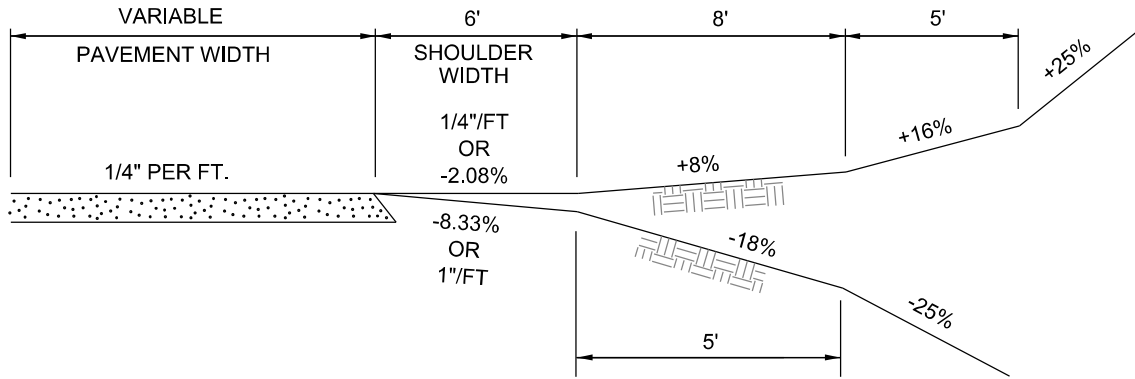

B. SHOULDER SECTION

NOTES:

IF THE SLOPE BETWEEN THE TOP OF CURB AND GUTTER AND A POINT 30 FEET FROM THE CURB AND GUTTER EXCEEDS 20%, THIS SLOPE SHALL BE ADJUSTED TO A MAXIMUM OF 8.33% (1"/FT) UP OR 4.17% (1/2" /FT) DOWN.

CITY OF RALEIGH		
STANDARD DETAIL		
REVISIONS	DATE: 8/2020	NOT TO SCALE
DATE: 12/2022	DRIVEWAY GRADES	
T-10.04		