

CROSS SLOPE NOT TO EXCEED 1.5% (2.08% MAX) ON ANY PORTION OF RAMP OR TRANSITION TO STREET.

TYPE N-4

- ① 7.5%; 8.33% (1:12) MAX RAMP SLOPE
- ② 1.5%; 2.08% (1:48) MAX CROSS SLOPE
- ③ CURB RAMPS REQUIRE A (4'-0") MINIMUM LANDING WITH A MAXIMUM CROSS SLOPE AND LONGITUDINAL SLOPE OF 1.5% (2.08% MAX) WHERE PEDESTRIANS PERFORM TURNING MANEUVERS. SLOPE TO DRAIN TO CURB.
- ④ RAMPS AND DOMES SHALL BE INSTALLED THE SAME WIDTH AS THE SIDEWALK.
- ⑤ IF LENGTH EXCEEDS 5', TRUNCATED DOMES SHALL BE INSTALLED ALONG THE BACK OF THE CURB COVERING THE FULL WIDTH OF THE RAMP.

CONCRETE DEPTH	
RAMP	6"
LANDING	4"

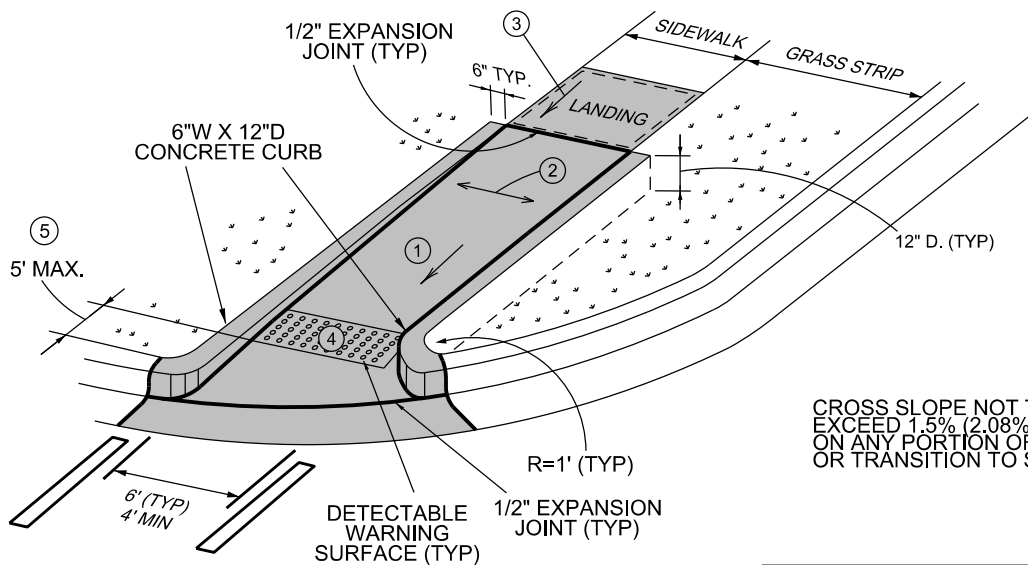

CROSS SLOPE NOT TO EXCEED 1.5% (2.08% MAX) ON ANY PORTION OF RAMP OR TRANSITION TO STREET.

TYPE N-4A

CITY OF RALEIGH STANDARD DETAIL		
REVISIONS	DATE: 8/2020	NOT TO SCALE
DATE: 12/2022	CURB RAMPS (NEW DEVELOPMENT)	
T-20.01.4		