

**SMALL RADIUS
LESS THAN 15'**

CONCRETE DEPTH	
SIDE RAMPS	4"
LANDING & CURB RAMPS	6"

- ① 7.5%; 8.33% (1:12) MAX RAMP SLOPE
- ② 1.5%; 2.08% (1:48) MAX CROSS SLOPE
- ③ CURB RAMPS REQUIRE A (4'-0") MINIMUM LANDING WITH A MAXIMUM CROSS SLOPE AND LONGITUDINAL SLOPE OF 1.5% (2.08% MAX) WHERE PEDESTRIANS PERFORM TURNING MANEUVERS. SLOPE TO DRAIN TO CURB.
- ④ RAMPS AND DOMES SHALL BE INSTALLED THE SAME WIDTH AS THE SIDEWALK.

CROSS SLOPE NOT TO EXCEED 1.5% (2.08% MAX) ON ANY PORTION OF RAMP OR TRANSITION TO STREET.

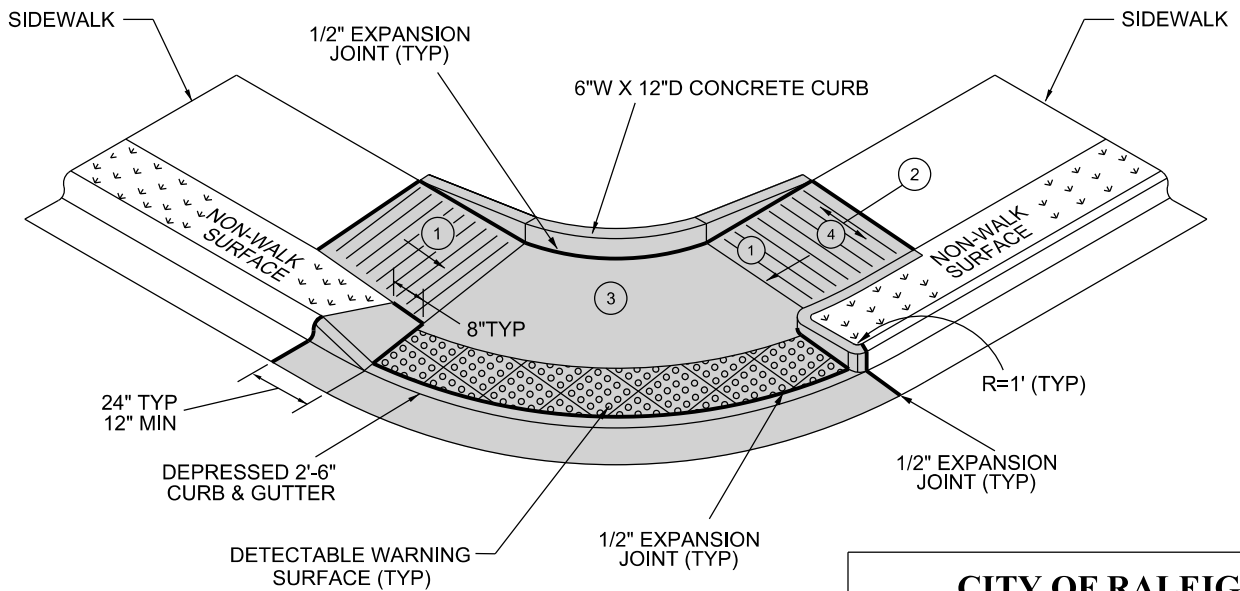

**LARGER RADIUS
15' OR GREATER**

**ONLY TO BE USED WITH
CITY OF RALEIGH APPROVAL.**

CITY OF RALEIGH STANDARD DETAIL		
REVISIONS	DATE: 8/2020	NOT TO SCALE
DATE: 12/2022	SHARED CURB RAMP/FLARE (RETROFIT)	
T-20.01.7		