

PLAN VIEW

SAW CUT JOINT SPACING @ 10' O.C.

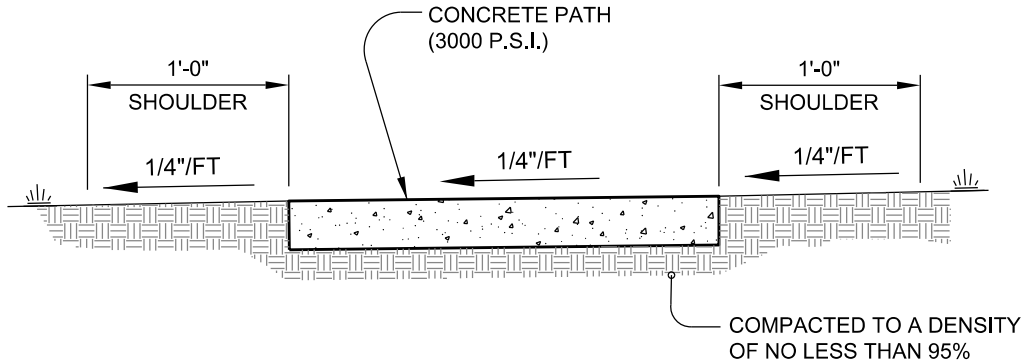

TYPICAL SECTION

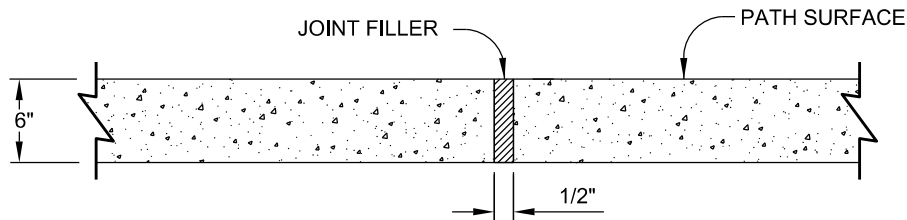

TRANSVERSE EXPANSION JOINT

NOTES:

1. TRANSVERSE EXPANSION JOINTS TO BE A MAXIMUM OF 50 FEET APART.
2. ALL CONCRETE TO BE FINISHED WITH CURING COMPOUND.
3. A 6 INCH DEPTH IS REQUIRED.
4. SAW CUT JOINTS EVERY 10 FEET OR SAME AS WIDTH. WHICHEVER IS LESS.
5. NO UTILITY SURFACE COVERS/PLATES/MANHOLES (i.e. WATERLINE VALVE COVERS, ETC.) SHALL BE LOCATED WITHIN PATH AND SHALL BE MINIMUM 1 FOOT FROM THE EDGE OF PATH.
6. ALL PATHS SHALL BE LOCATED MINIMUM 6 FEET FROM THE BACK OF CURB.
7. MULTI-USE PATH WIDTH TO BE DETERMINED BY CITY OF RALEIGH BASED ON ROADWAY TYPE, LOCATION AND PEDESTRIAN VOLUMES.

SHEET 2 OF 2

CITY OF RALEIGH		
STANDARD DETAIL		
REVISIONS	DATE: 8/2020	NOT TO SCALE
DATE: 12/2022	CONCRETE MULTI-PURPOSE PATH	
T-30.02.2		