

CITY OF RALEIGH

STANDARD DETAILS

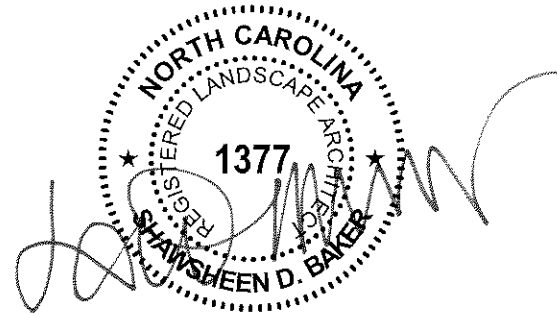

TREE PROTECTION AND PLANTING

8" MAX.
VARIABLE AS DIRECTED BY THE ENGINEER

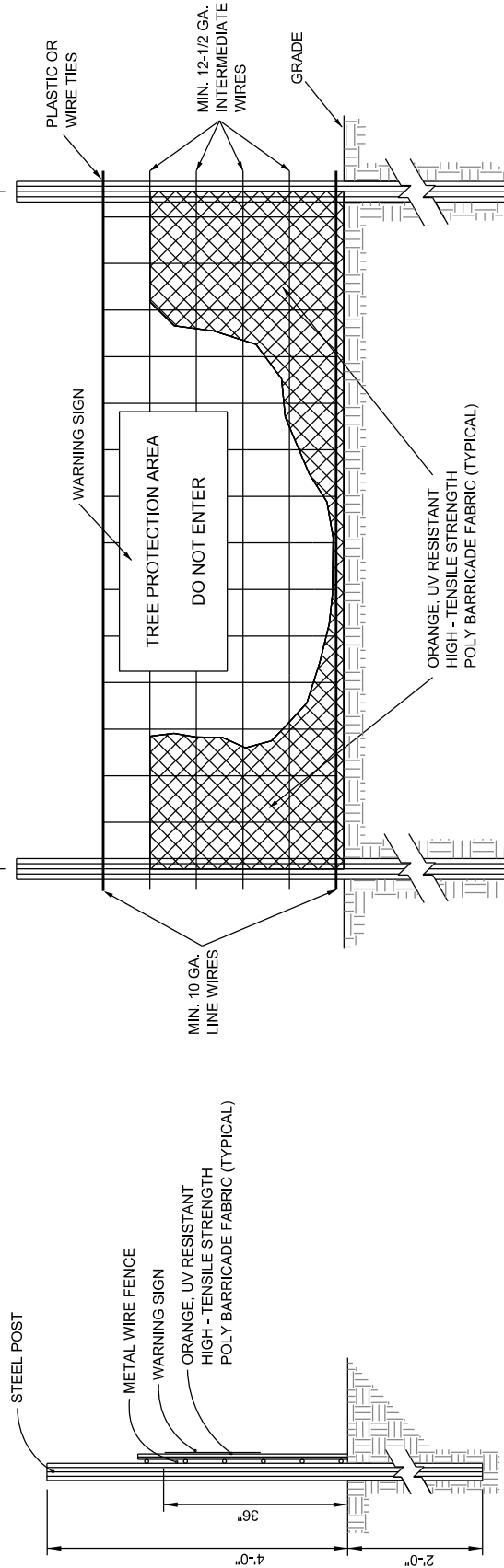

FRONT VIEW

SIDE VIEW

PROVIDE WARNING LANGUAGE IN BOTH ENGLISH AND SPANISH, AS SHOWN

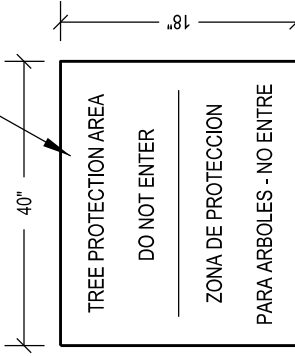

WARNING SIGN DETAIL

NOTE: FOR TREE PROTECTION ONLY

NOTES:

1. TREE PROTECTION FENCING MUST BE INSTALLED AT A MINIMUM RADIUS OF THE CRITICAL ROOT ZONE (SEE DETAIL TPP-02 FOR EXAMPLES)
2. THE TREE PROTECTION FENCING MUST REMAIN IN PLACE FOR THE DURATION OF THE PROJECT UNLESS OTHERWISE APPROVED BY URBAN FORESTRY STAFF.
3. APPROVED IMPACT PROTECTION DEVICES MUST BE REMOVED AFTER CONSTRUCTION WHEN APPLICABLE.
4. SIGNS SHALL BE PLACED AT 50' MAXIMUM INTERVALS. PLACE A SIGN AT EACH END OF LINEAR TREE PROTECTION AND 50' ON CENTER FOR THE REMAINDER
5. FOR TREE PROTECTION AREAS LESS THAN 200' IN PERIMETER, PROVIDE NO LESS THAN ONE SIGN PER PROTECTED AREA.
6. ATTACH SIGNS SECURELY TO FENCE POSTS AND FABRIC.
7. ADDITIONAL SIGNS MAY BE REQUIRED BY CITY OF RALEIGH BASED ON ACTUAL FIELD CONDITIONS.
8. SIGNS ARE TO BE MADE OF DURABLE, WEATHERPROOF MATERIAL WITH LETTERS A MINIMUM OF 2 1/2" HIGH, CLEARLY LEGIBLE AND SPACED AS SHOWN.

| CITY OF RALEIGH STANDARD DETAIL | | |
|------------------------------------|--------------|--------------|
| REVISIONS | DATE: 8/2020 | NOT TO SCALE |
| STANDARD TREE PROTECTION DETAIL | | |
| TPP-01 | | |

CONTACT INFORMATION:
CITY OF RALEIGH PARKS, RECREATION AND CULTURAL RESOURCES DEPARTMENT
URBAN FORESTER:
TREES@RALEIGHNC.GOV
WWW.RALEIGHNC.GOV

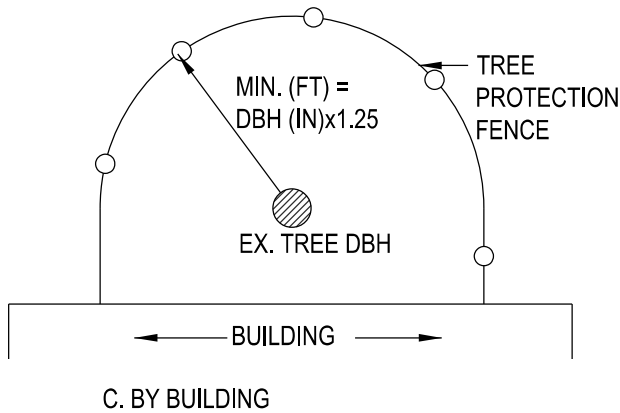
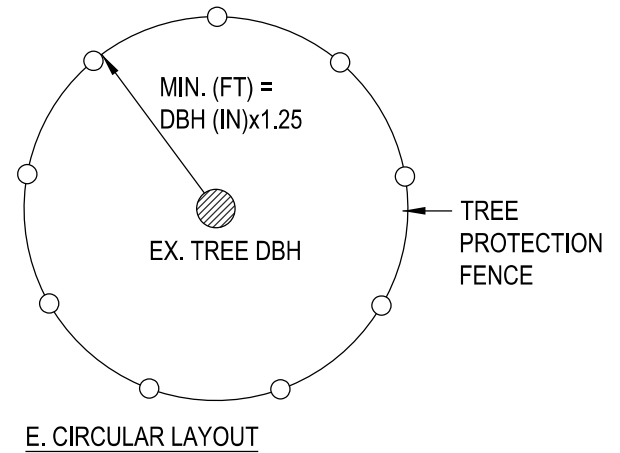
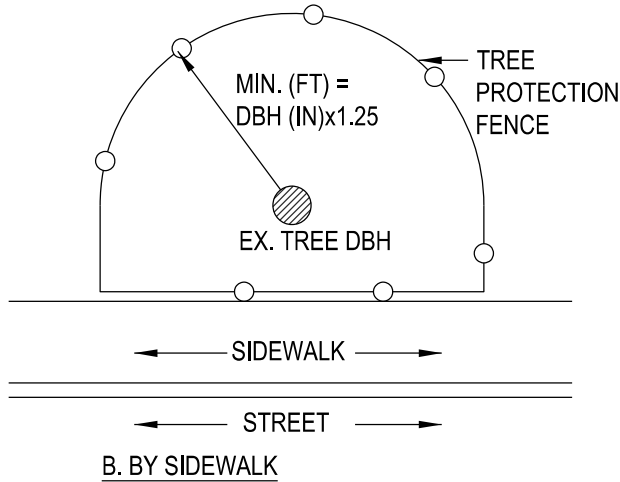
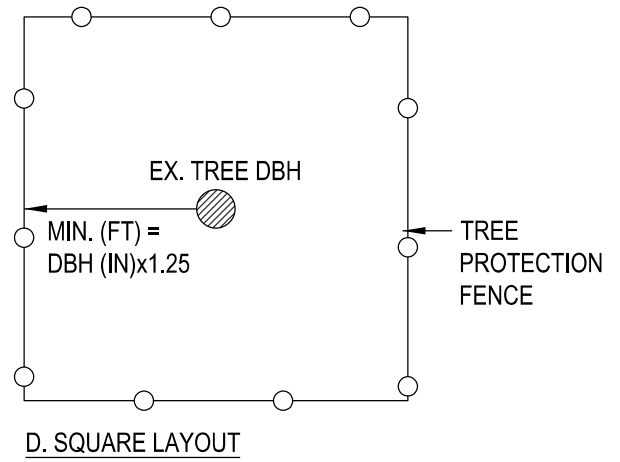
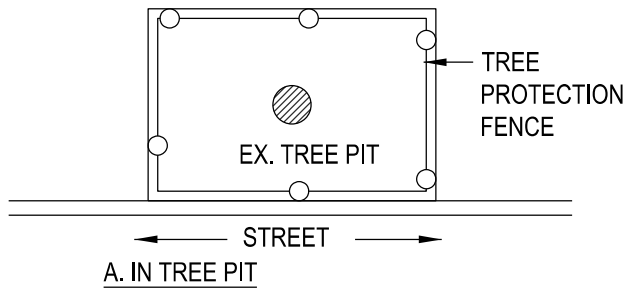

CONTACT INFORMATION:
 CITY OF RALEIGH PARKS, RECREATION AND
 CULTURAL RESOURCES DEPARTMENT
 URBAN FORESTER: TREES@RALEIGHNC.GOV
 WWW.RALEIGHNC.GOV

NOTES:

1. CONTRACTOR MUST PROVIDE AND INSTALL TREE PROTECTION SIGNAGE.
2. A TREE IMPACT PERMIT IS REQUIRED PRIOR TO INITIATION OF CONSTRUCTION IF ANY TREES ON CITY PROPERTY ARE TO BE IMPACTED BY PRUNING, TRENCHING, BORING, REMOVAL, PAVING, PLANTING, ETC.

| CITY OF RALEIGH STANDARD DETAIL | | |
|------------------------------------|--------------|---------------------------------|
| REVISIONS | DATE: 8/2020 | NOT TO SCALE |
| | | TREE PROTECTION FENCE LAYOUT |
| | | TPP-02 |

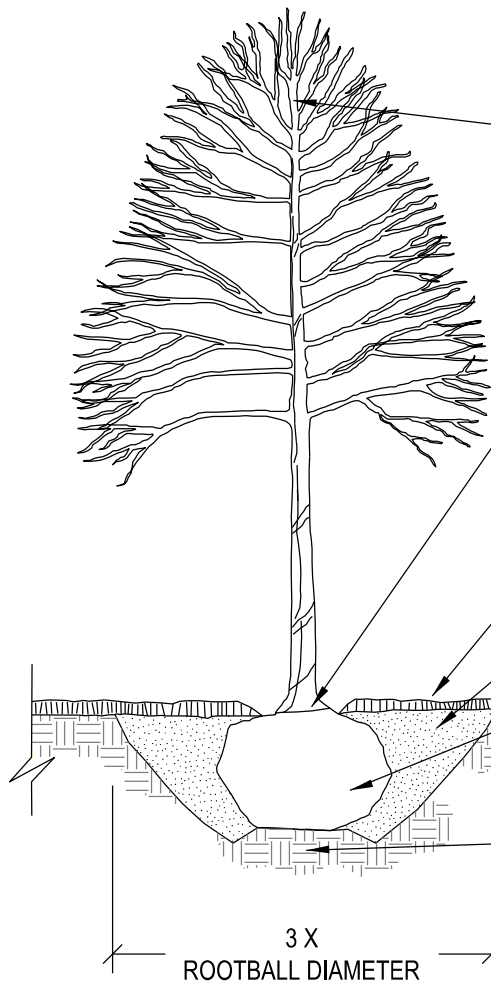

DO NOT PRUNE LEADER. PRUNE OR CUT ONLY DEAD OR DAMAGED BRANCHES TO AMERICAN NATIONAL STANDARDS INSTITUTE (ANSI) A300 STANDARDS

REMOVE EXCESS SOIL TO EXPOSE THE ROOT FLARE. THE ROOT FLARE SHALL BE PLANTED AT GRADE, NO HIGHER THAN 2" ABOVE GRADE, AND NEVER BELOW GRADE. TREE SHALL BE SET PLUMB

MULCH DEPTH NOT MORE THAN 3". KEEP MULCH 3" FROM ROOT FLARE AND DO NOT CONTACT STEM

PLANTING SOIL MIX AROUND ROOT BALL. 600 CU FT OF SOIL OR STRUCTURAL SOIL REQUIRED PER TREE

COMPLETELY REMOVE TOP HALF OF BURLAP, LACING STRAPS, NAILS AND WIRE BASKET AND DISCARD FROM HOLE. ALL SYNTHETIC BURLAP MUST BE REMOVED FROM SIDES OF ROOT BALL.

ROOT BALL SHALL BE PLACED DIRECTLY ON COMPACTED SUBGRADE. HANDLE TREE BY THE ROOT BALL ONLY.

3 X
ROOTBALL DIAMETER

CONTACT INFORMATION:
CITY OF RALEIGH PARKS, RECREATION AND CULTURAL RESOURCES DEPARTMENT URBAN FORESTER:
TREES@RALEIGHNC.GOV
WWW.RALEIGHNC.GOV

NOTES:

1. TREES MUST MEET THE TREE QUALITY STANDARDS IN CH. 2 OF THE CITY TREE MANUAL.
2. CONTRACTOR IS RESPONSIBLE FOR ADEQUATE DRAINAGE OF ALL PLANTING PITS. (POSITIVE DRAINAGE AWAY FROM PIT)
3. TREES SHALL BE PLANTED BETWEEN OCTOBER 1ST AND APRIL 30TH.
4. A TREE IMPACT PERMIT IS REQUIRED.
5. ELECTRICAL OUTLETS AND OTHER UTILITIES ARE PROHIBITED IN THE PLANTING AREA IMMEDIATELY SURROUNDING THE TREE.
6. IF STAKING IN ACCORDANCE WITH THE CITY TREE MANUAL, THE STAKING MUST BE REMOVED WITHIN ONE YEAR
7. TREES WILL HAVE A MINIMUM 1 YEAR WARRANTY AFTER THE INITIAL PLANTING IS APPROVED BY THE CITY.

| CITY OF RALEIGH STANDARD DETAIL | | |
|--|-----------------------------|--------------|
| REVISIONS | DATE: 8/2020 | NOT TO SCALE |
| 10/2019 | TREE PLANTING DETAIL | |
| | | |
| | | |
| | | |
| | | |
| TPP-03 | | |

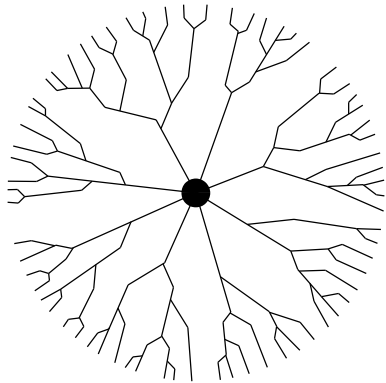

PLAN

CRITICAL ROOT ZONE

CRITICAL ROOT ZONE

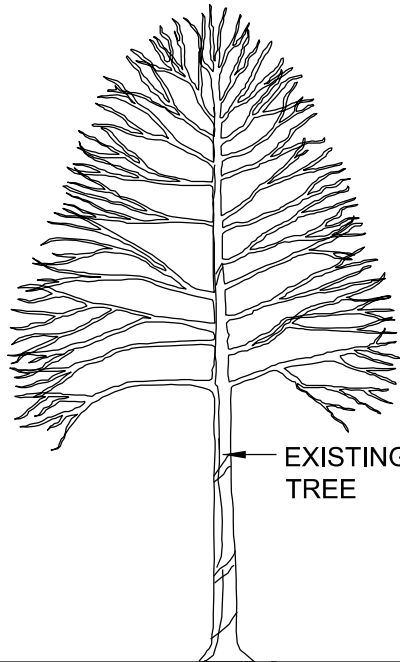

EXISTING TREE

30" MINIMUM

TUNNELING/BORING PERMITTED

SECTION

NOTES:

1. THE CRITICAL ROOT ZONE (CRZ) IS DEFINED AS A RADIUS EXTENDING FROM THE TRUNK OF A TREE 1.25 FEET PER INCH OF DBH.
2. TRENCHING SHALL OCCUR OUTSIDE THE CRZ
 - 2.1. TUNNELING AND BORING IS PERMITTED WITHIN THE CRZ AS LONG AS IT IS 30 INCHES DEEP OR GREATER. EXCAVATIONS AND HAND HOLES SHALL BE OUTSIDE THE CRZ.
 - 2.2. ENCROACHMENT INTO THE CRZ REQUIRES APPROVAL FROM THE URBAN FORESTER
3. ROOTS MUST BE PRUNED TO A CLEAN CUT. CUTTING OR PRUNING OF ROOTS 2" OR LARGER IS PROHIBITED.
4. IF EXCAVATION CAUSES PRUNED ROOTS OVER 1.5" IN DIAMETER TO REMAIN EXPOSED FOR MORE THAN 24 HOURS, ROOTS ON TREE SIDE MUST BE KEPT MOIST.
5. A TREE IMPACT PERMIT IS REQUIRED PRIOR TO INITIATION OF CONSTRUCTION IF ANY TREES ON CITY PROPERTY ARE TO BE IMPACTED BY PRUNING, TRENCHING, BORING, REMOVAL, PAVING, PLANTING, ETC.

TRENCHING IS PERMITTED OUTSIDE OF THE CRZ

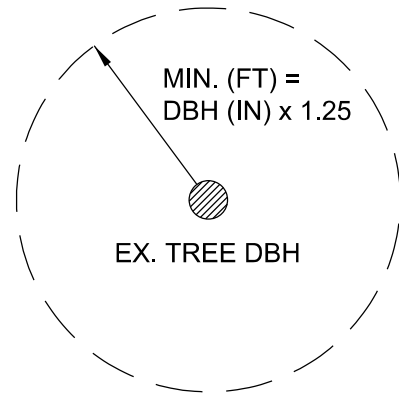

CRITICAL ROOT ZONE

CONTACT INFORMATION:
 CITY OF RALEIGH PARKS, RECREATION AND
 CULTURAL RESOURCES DEPARTMENT URBAN
 FORESTER: TREES@RALEIGHNC.GOV
 WWW.RALEIGHNC.GOV

| CITY OF RALEIGH STANDARD DETAIL | | |
|------------------------------------|--|---------------|
| REVISIONS | DATE: 8/2020 | NOT TO SCALE |
| | TRENCHING/TUNNELING NEAR EXISTING TREES | |
| | | |
| | | |
| | | |
| | | TPP-04 |

GRAY IRON, RECTANGULAR 4'X6', 1.5" MIN. THICK, WITH 1/4" OPENING OR LESS

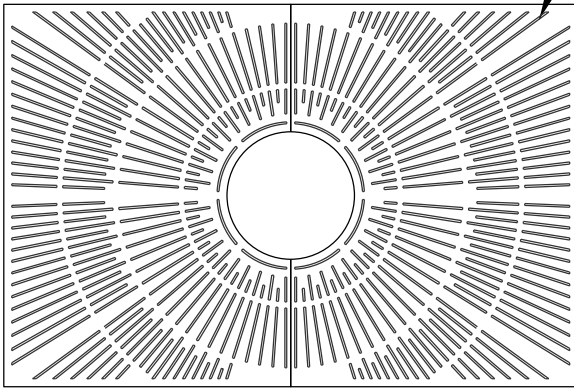

NOTES:

1. GRATE DESIGN MUST BE ADA COMPLIANT.
2. GENERAL PATTERN DESIGN MUST BE AS SHOWN.
3. EXCEPTIONS OR PERSONALIZATION MUST BE REVIEWED AND APPROVED BY THE CITY OF RALEIGH.
4. A TREE IMPACT PERMIT IS REQUIRED.
5. ADHERE TO STANDARDS IN THE CITY TREE MANUAL.
6. ELECTRIC OUTLETS AND OTHER UTILITIES ARE PROHIBITED IN THE GRATE AREA.

CONTACT INFORMATION:

CITY OF RALEIGH PARKS, RECREATION AND CULTURAL RESOURCES DEPARTMENT URBAN FORESTER:TREES@RALEIGHNC.GOV WWW.RALEIGHNC.GOV

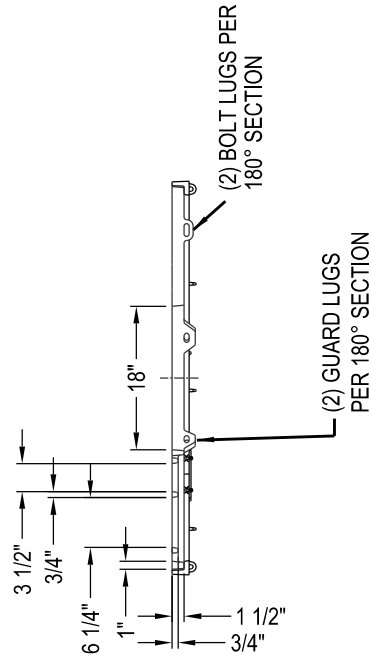
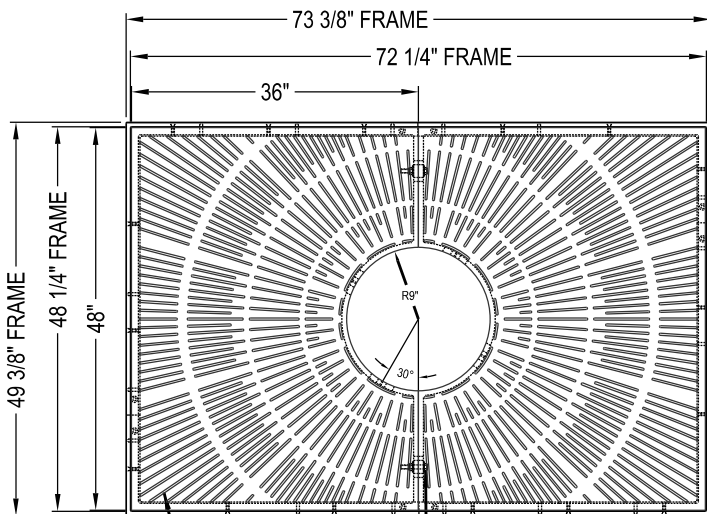

BOLT TREE GRATE HALVES TOGETHER w/ (2) 1/2"-13 x 3" STNL. STL. HEX BOLTS, GALV. FLAT WASHERS AND STNL. STL. HEX NUT

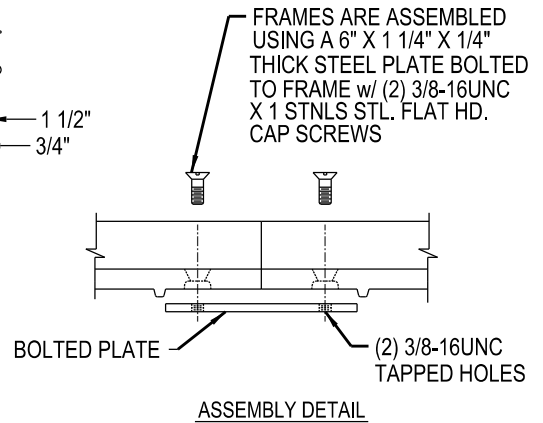
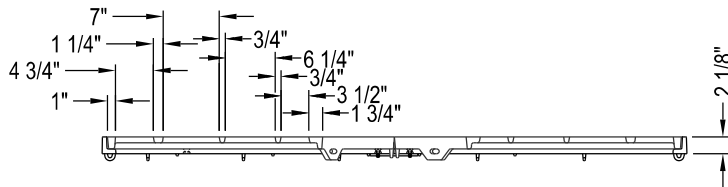

NOTE: ALL DIMENSIONS SHOWN ARE IN ENGLISH
 MATERIAL: CAST GRAY IRON ASTM A-48, CLASS 35B
 FINISH: NO PAINT
 WEIGHT: 608#/SET

| CITY OF RALEIGH STANDARD DETAIL | | |
|------------------------------------|--------------------------------------|--------------|
| REVISIONS | DATE: 8/2020 | NOT TO SCALE |
| | TREE GRATE IN SIDEWALK WITHIN ROW | |
| | | |
| | | |
| | | |
| TPP-06 | | |

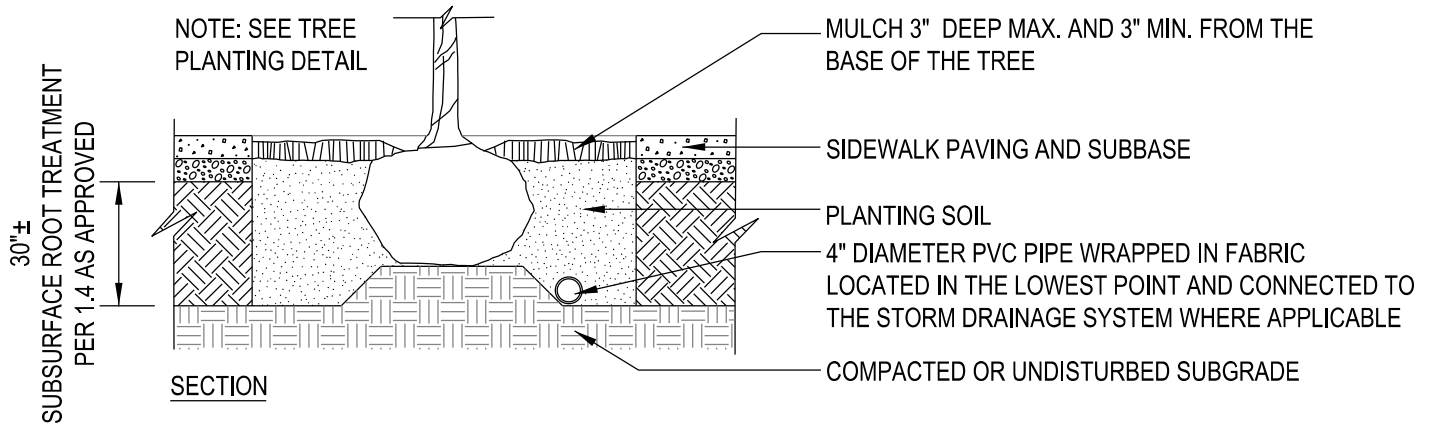

NOTES:

1. A SITE SPECIFIC PLAN MUST BE DEVELOPED TO ENSURE THAT:
 - 1.1. EACH TREE IS PROVIDED A MIN. ROOT-ACCESSIBLE SOIL VOLUME OF 600 CUBIC FEET.
 - 1.2. THE TREE ROOT AREA BENEATH THE SIDEWALK IS EXPANDED TO MAXIMIZE ROOT ACCESSIBLE SOIL SPACE UNDER THE PAVEMENT.
 - 1.3. CONNECT SOIL SPACE FOR ROOT EXPANSION WHERE POSSIBLE TO ALLOW ROOT SYSTEMS OF TREES TO OVERLAP AND COLONIZE A SHARED SOIL SPACE.
 - 1.4. ANY COMBINATION OF STRUCTURAL SOILS, SOIL CONTAINMENT SYSTEM (e.g., SILVA CELL), OR ROOT CHANNELING (e.g., SOIL STRIP DRAIN/AERATION SYSTEM) THAT PERFORMS AS SPECIFIED IS ACCEPTABLE.
3. 40' X 6' WIDTH MINIMUM APPLIES TO BOTH STRUCTURAL SOILS AND SUBSURFACE SOIL CONTAINMENT SYSTEMS.
4. SUBSURFACE APPLICATION SHALL BE REVIEWED AND APPROVED BY CITY OF RALEIGH PARKS, RECREATION AND CULTURAL RESOURCES URBAN FORESTRY DIVISION PRIOR TO INSTALLATION.

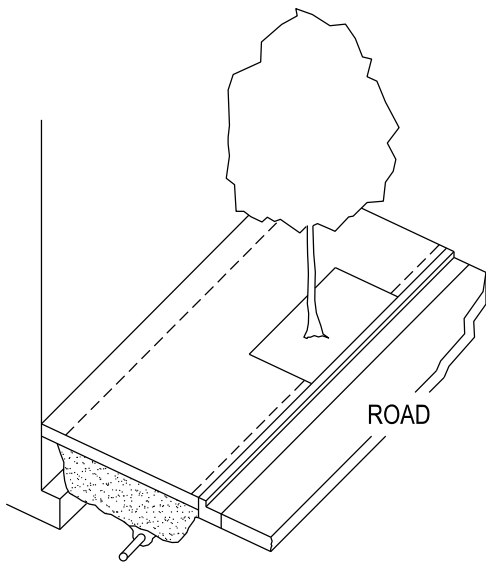

STRUCTURAL SOIL SYSTEM

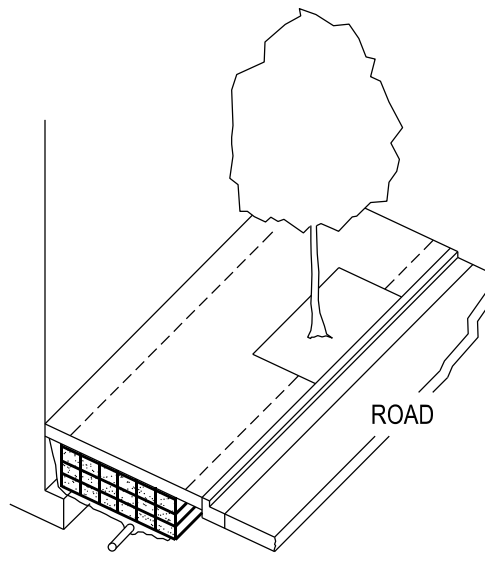

SOIL CONTAINMENT SYSTEM

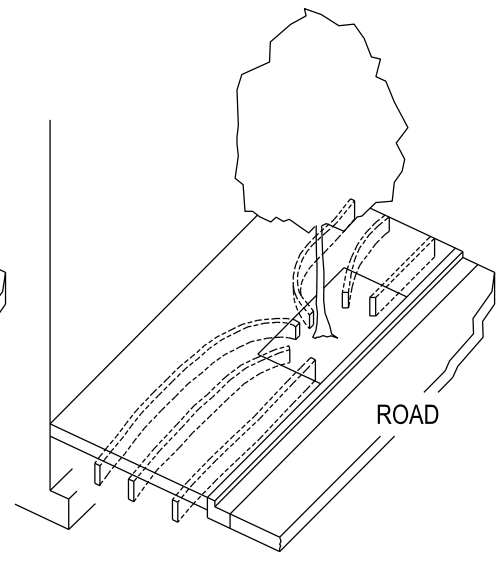

ROOT CHANNELING/PATHWAYS

CONTACT INFORMATION:
 CITY OF RALEIGH PARKS, RECREATION AND CULTURAL RESOURCES DEPARTMENT
 URBAN FORESTER: TREES@RALEIGHNC.GOV
 WWW.RALEIGHNC.GOV

| CITY OF RALEIGH STANDARD DETAIL | | |
|------------------------------------|---|--------------|
| REVISIONS | DATE: 8/2020 | NOT TO SCALE |
| | TREE PLANTING IN SIDEWALK WITHIN ROW | |
| | | |
| | | |
| | | |
| TPP-07 | | |

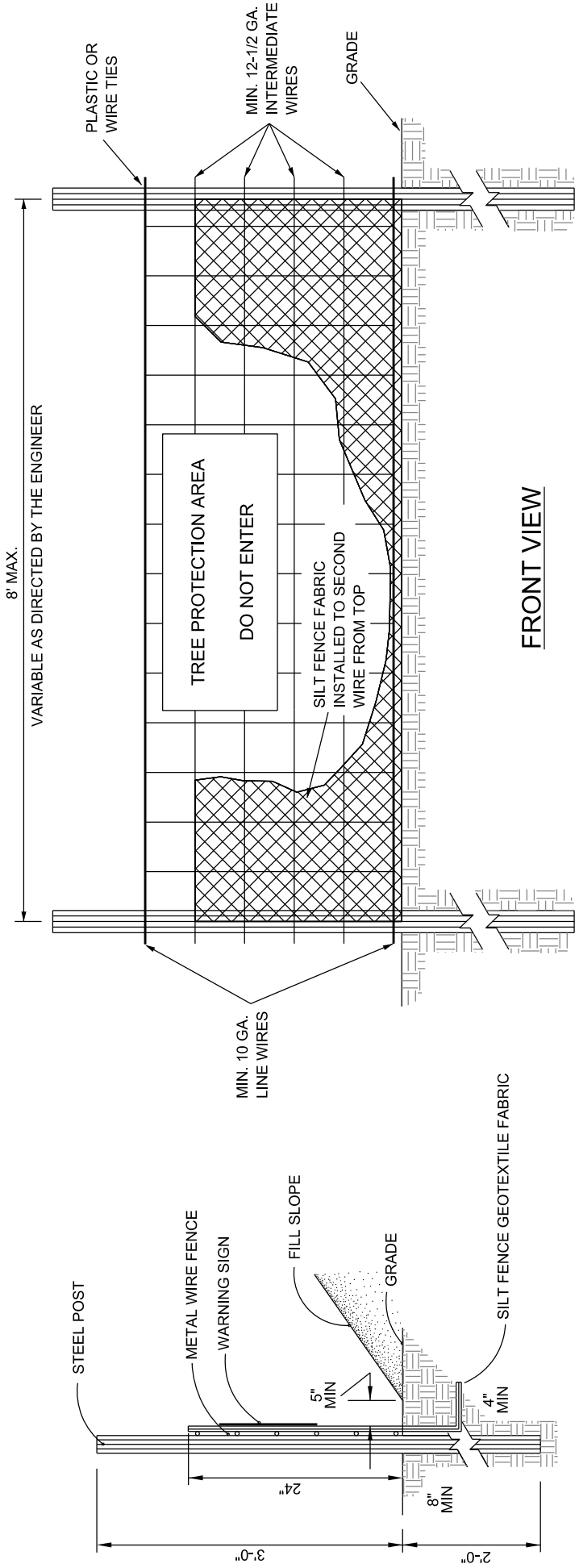

FRONT VIEW

SIDE VIEW

MAINTENANCE: CLEAN OUT AT 50% CAPACITY
 LIFE OF FENCING: 6-9 MONTHS
 DO NOT DISTURB TREE CONSERVATION AREAS
 SILT FENCE SHOULD NOT BE USED ALONE BELOW
 GRADED SLOPES GREATER THAN 10' IN HEIGHT.

NOTES:

1. TREE PROTECTION FENCING MUST BE INSTALLED AT A MINIMUM RADIUS OF THE CRITICAL ROOT ZONE (SEE DETAIL TPP-02 FOR EXAMPLES)
2. THE TREE PROTECTION FENCING MUST REMAIN IN PLACE FOR THE DURATION OF THE PROJECT UNLESS OTHERWISE APPROVED BY URBAN FORESTRY STAFF.
3. APPROVED IMPACT PROTECTION DEVICES MUST BE REMOVED AFTER CONSTRUCTION WHEN APPLICABLE.
4. SIGNS SHALL BE PLACED AT 50' MAXIMUM INTERVALS. PLACE A SIGN AT EACH END OF LINEAR TREE PROTECTION AND 50' ON CENTER FOR THE REMAINDER
5. FOR TREE PROTECTION AREAS LESS THAN 200' IN PERIMETER, PROVIDE NO LESS THAN ONE SIGN PER PROTECTED AREA.
6. ATTACH SIGNS SECURELY TO FENCE POSTS AND FABRIC.
7. ADDITIONAL SIGNS MAY BE REQUIRED BY CITY OF RALEIGH BASED ON ACTUAL FIELD CONDITIONS.
8. SIGNS ARE TO BE MADE OF DURABLE, WEATHERPROOF MATERIAL WITH LETTERS A MINIMUM OF 2 1/2" HIGH, CLEARLY LEGIBLE AND SPACED AS SHOWN.
9. FLOW SHALL NOT RUN PARALLEL WITH THE FENCE. END OF SILT FENCE NEEDS TO BE TURNED UPHILL.
10. SEE NC STATE DEQ PRACTICE STANDARDS & SPECIFICATIONS SEDIMENT FENCE SET FOR CONDITIONS WHERE APPLIES: PLANNING CONSIDERATIONS & DESIGN CRITERIA. (HOWEVER, FLOW SHALL NOT RUN PARALLEL WITH THE TOE OF THE FENCE.)

PROVIDE WARNING
 LANGUAGE IN BOTH
 ENGLISH AND SPANISH,
 AS SHOWN

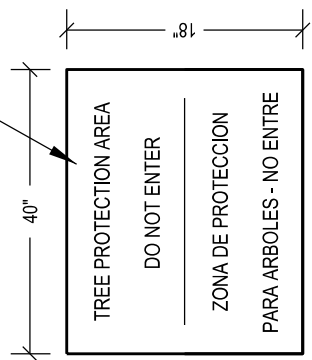

WARNING SIGN DETAIL

CONTACT INFORMATION:
 CITY OF RALEIGH PARKS, RECREATION AND
 CULTURAL RESOURCES DEPARTMENT
 URBAN FORESTER:
 TREES@RALEIGHNC.GOV
 WWW.RALEIGHNC.GOV

| | |
|------------------------|--|
| CITY OF RALEIGH | |
| STANDARD DETAIL | |
| REVISIONS | DATE: 8/2020 NOT TO SCALE |
| | STANDARD TEMPORARY (SEDIMENT/SILT) / TREE PROTECTION FENCE |
| TPP-08 | |

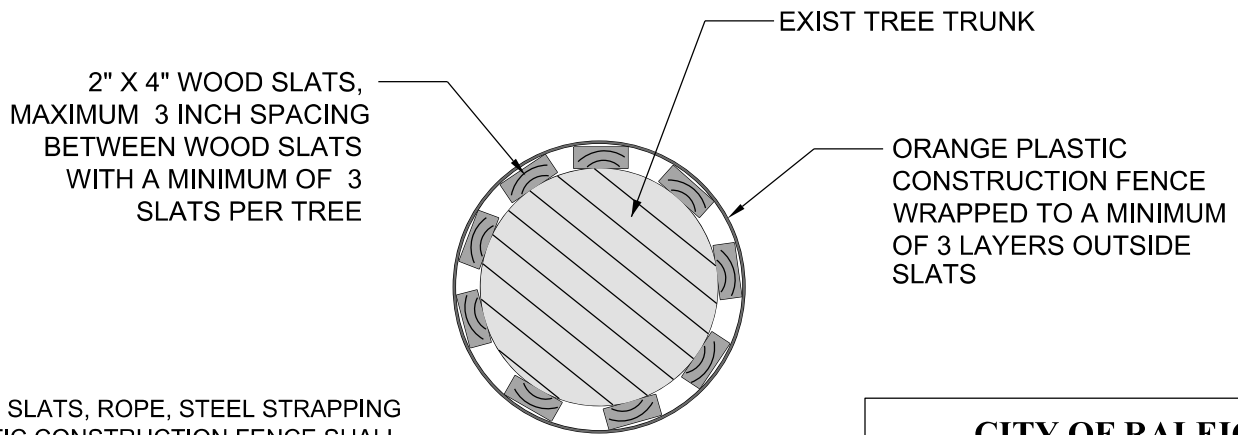
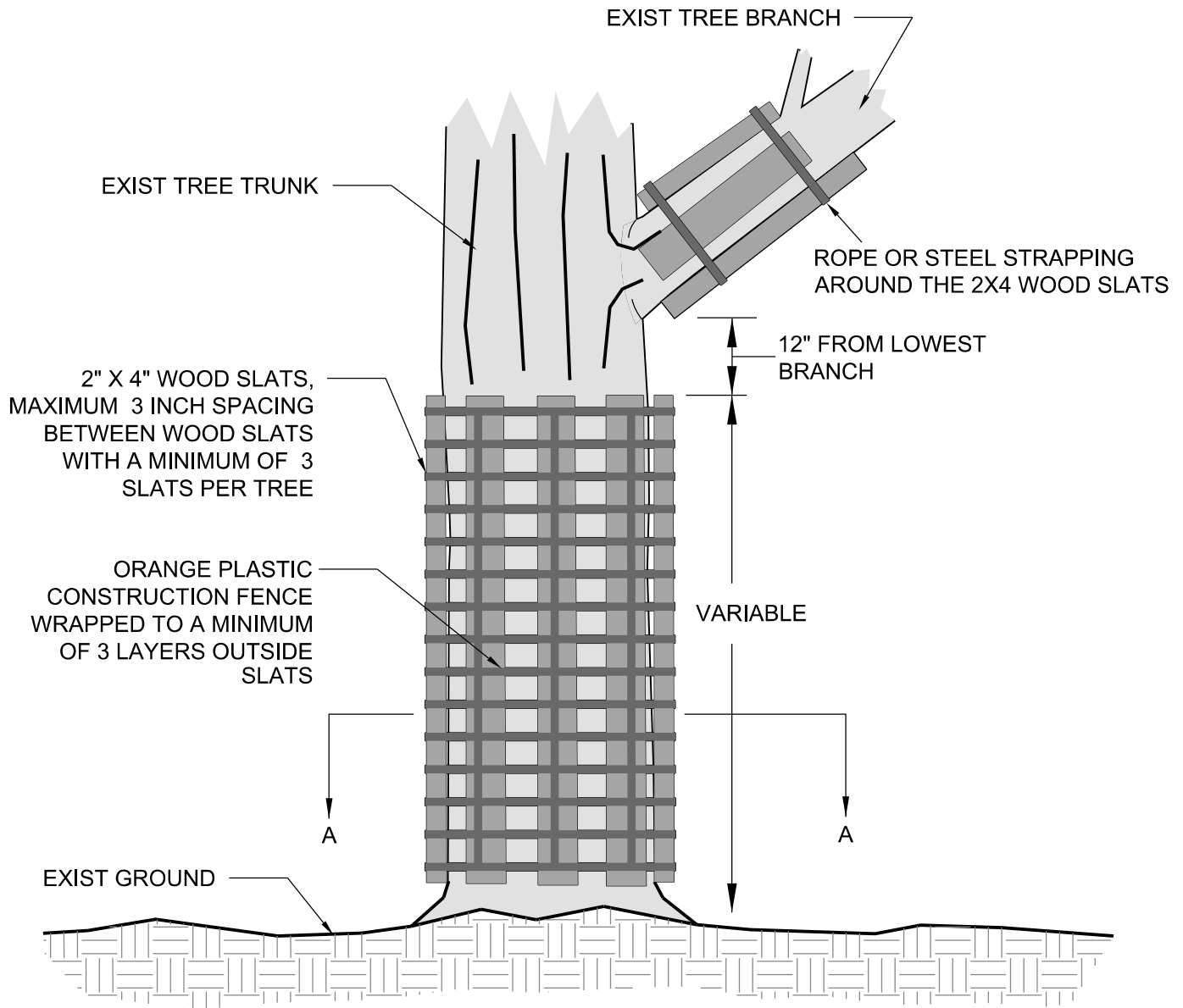

SECTION A - A

NOTE: NO SLATS, ROPE, STEEL STRAPPING OR PLASTIC CONSTRUCTION FENCE SHALL BE ATTACHED TO, ANCHORED TO OR TIED TO THE TREE.

CONTACT INFORMATION:
 CITY OF RALEIGH PARKS, RECREATION AND CULTURAL RESOURCES DEPARTMENT
 URBAN FORESTER: TREES@RALEIGHNC.GOV
 WWW.RALEIGHNC.GOV

| CITY OF RALEIGH STANDARD DETAIL | | |
|------------------------------------|--------------|---------------|
| REVISIONS | DATE: 8/2020 | NOT TO SCALE |
| | | TREE ARMOUR |
| | | TPP-09 |