

TYPICAL NOTES:

- 1)-ALL PIPING AND FITTINGS TO BE DUCTILE IORN, GALVANIZED, BRASS, STAINLESS STEEL, OR ALUMINIUM
- 2)-ALL PIPING AND FITTINGS TO BE DUCTILE IORN ON CITY SIDE OF BACK FLOW PREVENTION ASSEMBLY
- 3)-40' MAX. FROM FDC TO APPARATUS ACCESS LOCATION
- 4)-FDC TO FACE FIRE APPARATUS ACCESS LOCATION (DRIVEWAY)
- 5)-DO NOT BLOCK APPARATUS ACCESS TO BUILDING WITH HOSE LAY FROM HYDRANT TO FDC
- 6)-MINIMUM DISTANCE 3 FEET BEHIND CURB, PROTECT FROM VEHICLES
- 7)-PROVIDE HEAT AND ALARM SUPERVISION TO HOT BOX (2 CONDUITS)
- 8)-COMPLY WITH PUBLIC UTILITIES HANDBOOK REQUIREMENTS

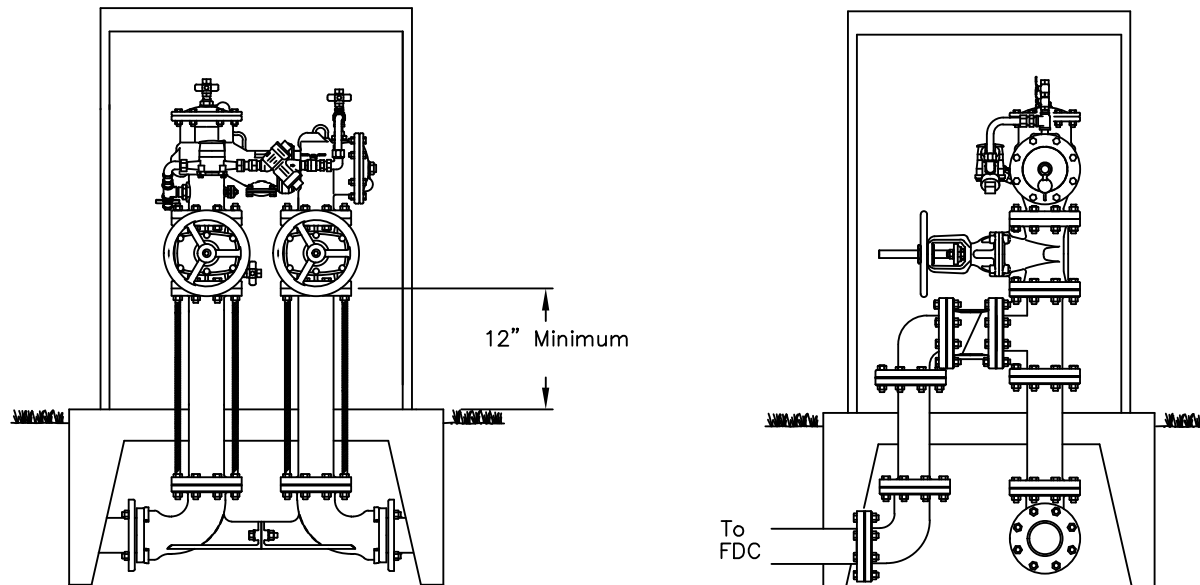

CITY OF RALEIGH FIRE DEPARTMENT
FIRE PROTECTION DIVISION
310 WEST MARTIN ST. RALEIGH, NC 27602

DESCRIPTION:
HOTBOX DETAIL REQUIREMENTS

REVISIONS:
5-1-2017

DATE:
4-1-06

DRAWING NO.
FP-27