

TECHNICAL BULLETIN CITY OF RALEIGH, N.C. www.raleighnc.gov				OFFICE OF THE FIRE MARSHAL	
Subject	Bulletin #	SECTION	PAGE	EFFECTIVE DATE	
Fire Apparatus Access	TB-12	NCFPC	1 of 3	5/1/2012	
		PREPARED BY Office of the Fire Marshal			Revision Date 01/15/2021

1.0 **Purpose**

This policy is to provide an alternate method to meet the fire department apparatus access requirements in the North Carolina Fire Prevention Code (current adopted edition).

2.0 **Organization(s) Affected**

Raleigh Fire Department (Office of the Fire Marshal), site/civil engineers, contractors, architects.

3.0 **References**

Current adopted edition North Carolina Fire Prevention Code and International fire code commentary.

4.0 **Definitions**

4.1 Unless otherwise stated, the following definitions shall, for the purposes of this technical bulletin, have the meanings as shown in 4.0.

4.2 Inside turning radius: Radius of the smallest circle around which the vehicle can turn.

4.3 Outside turning radius: (wall to wall) Radius of the smallest circle inside of which the entire vehicle can turn. This measurement takes into account any front overhang due to chassis, bumper extensions and aerial devices.

5.0 **Requirements**

5.1 Approved fire apparatus access shall be provided for every facility, building or portion of a building hereafter constructed or moved into or within the jurisdiction. The fire apparatus road shall have an unobstructed width of not less than 20 feet except for approved security gates. An unobstructed vertical clearance of not less than 13 feet 6 inches. Approved fire apparatus access roads shall extend to within 150 feet of all portions of the facility and all portions of the exterior wall of the first story of the building as measured by an approved route around the exterior of the building. The fire code official may increase this distance to minimum of 200' if the building is equipped throughout with an approved NFPA 13 or NFPA 13R *automatic sprinkler system*.

5.2 Fire apparatus access roads shall be designed and maintained to support the imposed loads of the fire apparatus (90,000 pounds). Roads shall be surfaced to provide all weather driving capabilities in such a way that excessive rain does not cause it to be flooded; degraded due to wash out and/or wash-boarding; or, sodden to such an extent that fire apparatus travel would become compromised. Alternatives to asphalt and concrete, such as interlocking pavers, may be used when approved and for limited applications. A graveled surface is not an acceptable alternative and will not be considered for an approved alternative method.

5.3 The minimum required inside turning radius shall be 28 feet unless otherwise determined by the fire code official.

5.4 Dead end fire apparatus access roads exceeding 150 feet shall be provided with an approved area for turning around fire apparatus.

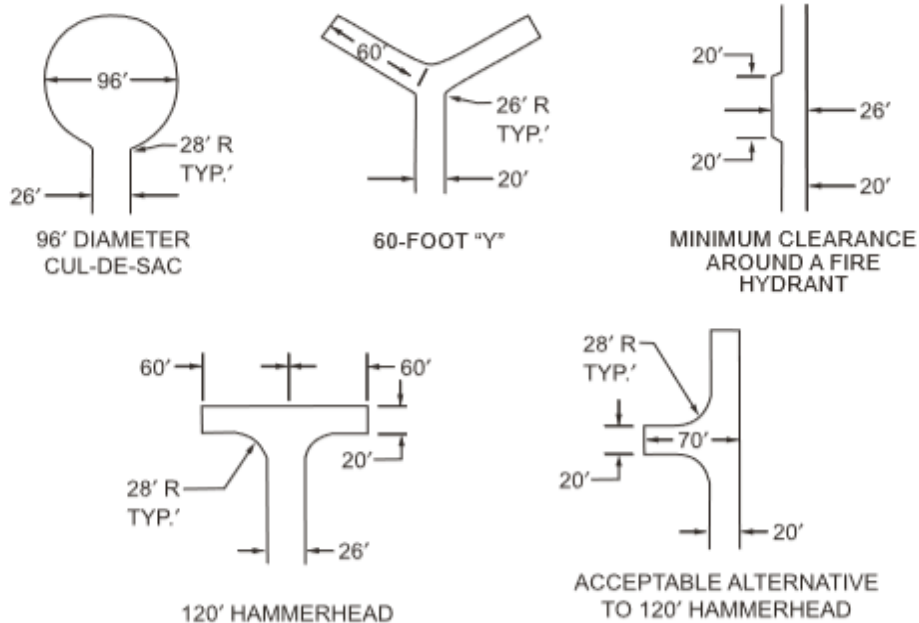

5.5 The grade of the fire apparatus access road shall not exceed 12 percent unless written permission is obtained from the fire code official.

5.6 Security gate installation across fire apparatus access roads shall be approved by the fire code official. Where security gates are installed they shall have an approved means of emergency operation.

5.7 Alternate access routes can be presented to the fire official for approval. Alternate plans must provide access for all fire apparatus in service with the Raleigh Fire Department (present and future).

- 5.8 FP-29 provides an alternate method of plotting access for an aerial apparatus on site plans. When using this alternate method access must be shown to be equivalent to the access required in 5.1- 5.6 above. The minimum inside turning radius is 24 feet 7 inches with an outside turning radius (wall to wall) of 47 feet 7 inches. The minimum access road width is 20 feet as shown on the detail. Obstructions such as guard houses, islands, security gates, etc. must be plotted to show that the apparatus can navigate the opening without backing up. Minimum of 2 feet clearance is required on both sides of the largest apparatus (14 feet).
- 6.0 **Goal:**
- 6.1 Our goal is to provide adequate emergency access for City of Raleigh Fire Apparatus to ensure that the fire departments mission of fire suppression, rescue, emergency medical services, and special services to all who live, visit, work, or invest in the city are provided without delay.
- 6.2 The goal of Alternate apparatus access is to provide flexibility to designers and allow both the owners needs and the needs of the fire department to be met in an approved manner.